

INDUSTRIAL ENGINE

TNV

**3TNV88C
3TNV86CT
3TNV86CHT
4TNV88C
4TNV86CT
4TNV86CHT
4TNV98C
4TNV98CT
4TNV94CHT**

California
Proposition 65 Warning

Diesel engine exhaust and some of its constituents are known to the state of California to cause cancer, birth defects, and other reproductive harm.

California
Proposition 65 Warning

Battery posts, terminals, and related accessories contain lead and lead compounds, chemicals known to the state of California to cause cancer and reproductive harm.
Wash hands after handling.

Disclaimers:

All information, illustrations and specifications in this manual are based on the latest information available at the time of publishing. The illustrations used in this manual are intended as representative reference views only. Moreover, because of our continuous product improvement policy, we may modify information, illustrations and/or specifications to explain and/or exemplify a product, service or maintenance improvement. We reserve the right to make any change at any time without notice. YANMAR and **YANMAR** are registered trademarks of YANMAR CO., LTD. in Japan, the United States and/or other countries.

All Rights Reserved:

No part of this publication may be reproduced or used in any form by any means - graphic, electronic, or mechanical, including photocopying, recording, taping, or information storage and retrieval systems - without the written permission of YANMAR CO., LTD.

When exporting or providing YANMAR products to non-residents, please comply with the security trade control laws and regulations of Japan and other relevant countries.

OPERATION MANUAL	MODEL	TNV Tier4 Common Rail Series
	CODE	0ATN4-EN0017

INTRODUCTION

Welcome to the world of YANMAR Engines! YANMAR has been the leader in industrial diesel engines for over 90 years. We developed the world's first practical small-sized diesel engine in 1933. Our engineers are continuously developing new technology to keep YANMAR on the leading-edge of the industry. The TNV engine is only one example of the new technology we have developed. We are committed to maintaining our environment, and are proud of our history of innovation, quality and respect for operator safety.

To help you enjoy your YANMAR TNV engine for many years to come, please follow these recommendations:

- Read and understand this Operation Manual before you operate the machine to ensure that you follow safe operating practices and maintenance procedures.
 - Keep this Operation Manual in a convenient place for easy access.
 - If this Operation Manual is lost or damaged, order a new one from your authorized YANMAR industrial engine dealer or distributor.
 - Make sure this manual is transferred to subsequent owners. This manual should be considered a permanent part of the engine and remain with it.
- Constant efforts are made to improve the quality and performance of YANMAR products, so some details included in this Operation Manual may differ slightly from your engine. If you have any questions about these differences, please contact your authorized YANMAR industrial engine dealer or distributor.
 - The specifications and components (instrument panel, fuel tank, etc.) described in this manual may differ from ones installed on your machine. Please refer to the manual provided by the manufacturer of these components.

INTRODUCTION

RECORD OF OWNERSHIP

Take a few moments to record the information you need when you contact YANMAR for service, parts or literature.

Engine model: _____

Engine serial No.: _____

Date purchased: _____

Dealer: _____

Dealer phone: _____

SYMBOL EXPLANATION

The following symbols are used throughout this manual to identify specific engine model information

- 3TNV88C
- 3TNV86CT
- 3TNV86CHT
- 4TNV88C
- 4TNV86CT
- 4TNV86CHT
- 4TNV98C
- 4TNV98CT
- 4TNV94CHT

TABLE OF CONTENTS

	Page
YANMAR WARRANTIES	1
YANMAR LIMITED WARRANTY	1
What is Covered by this Warranty?	1
How Long is the Warranty Period?	1
What the Engine Owner must Do:	2
To Locate an Authorized YANMAR Industrial Engine Dealer or Distributor:	2
What YANMAR will Do:	2
What is not Covered by this Warranty?	3
Warranty Limitations:	3
Warranty Modifications:	3
Questions:	3
EMISSION SYSTEM WARRANTY	4
YANMAR CO., LTD. Emission Control System Warranty - USA Only.....	4
Your Warranty Rights and Obligations:	4
Manufacturer's Warranty Period:.....	4
Warranty Coverage:	5
Warranted Parts:	5
Exclusions:	6
Owner's Warranty Responsibilities:.....	6
What the Emergency Stationary Type Engine Owner must Do:....	6
SAFETY	7
SAFETY STATEMENTS	7
SAFETY PRECAUTIONS	8
Before You Operate.....	8
During Operation and Maintenance.....	8

TABLE OF CONTENTS

PRODUCT OVERVIEW	19
YANMAR TNV ENGINE FEATURES AND APPLICATIONS	19
COMPONENT IDENTIFICATION	20
LOCATION OF LABELS	23
Engine Nameplate (Typical)	24
EMISSION CONTROL REGULATIONS	24
EPA/ARB Regulations - USA Only	24
EMISSION CONTROL LABELS	24
EPA/ARB Labels (Typical)	24
The 97/68/EC Directive Certified Labels	25
ENGINE FAMILY	25
FUNCTION OF MAJOR ENGINE COMPONENTS.....	26
FUNCTION OF COOLING SYSTEM COMPONENTS.....	27
ELECTRONIC CONTROL SYSTEM.....	28
Main Electronic Control Components and Features.....	30
Electronic Engine Speed Control	32
Diesel Particulate Filter (DPF).....	34
Intake Throttle	38
Exhaust Throttle	39
Installation Position of Sensors for Electronic Control System....	39
GAUGES AND INDICATORS	40
Gauges.....	40
Indicators and Switches	41
CONTROLS	44
Key Switch.....	44
Glow Plugs	45
BEFORE YOU OPERATE	47
DIESEL FUEL	48
Diesel Fuel Specifications	48
Filling the Fuel Tank	51
Priming the Fuel System	52
ENGINE LUBRICATING OIL	53
Engine Lubricating Oil Specifications	53
Engine Lubricating Oil Viscosity	53
Checking Engine Lubricating Oil	54
Adding Engine Lubricating Oil	54
Engine Lubricating Oil Capacity (Typical)	54
ENGINE COOLANT	55
Engine Coolant Specifications.....	56
Filling Radiator with Engine Coolant	56
Daily Check of the Cooling System	57
Engine Coolant Capacity (Typical)	57

DAILY CHECKS	58
Visual Checks.....	58
Check Diesel Fuel, Engine Lubricating Oil and Engine Coolant Levels.....	58
Check Engine Speed Control	58
Check Operator's Console	58
ENGINE OPERATION	61
STARTING ENGINE	62
CHECKING THE ENGINE DURING OPERATION	64
SHUTTING DOWN THE ENGINE.....	66
PERIODIC MAINTENANCE	67
PRECAUTIONS	68
The Importance of Periodic Maintenance.....	68
Performing Periodic Maintenance	68
The Importance of Daily Checks	68
Keep a Log of Engine Hours and Daily Checks	68
YANMAR Replacement Parts.....	68
Tools Required	68
Ask Your Authorized YANMAR Industrial Engine Dealer or Distributor for Help.....	68
Required EPA/ARB Maintenance USA Only	69
EPA/ARB Installation Requirements USA Only.....	69
Tightening Fasteners.....	69
STANDARD TORQUE CHART	69
PERIODIC MAINTENANCE SCHEDULE	70
Periodic Maintenance Chart	70
PERIODIC MAINTENANCE PROCEDURES	72
After Initial 50 Hours of Operation	72
Every 50 Hours of Operation	74
Every 250 Hours of Operation	76
Every 500 Hours of Operation	79
Every 1000 Hours of Operation	84
Every 1500 Hours of Operation	84
Every 2000 Hours of Operation	84
Every 3000 Hours of Operation	86
On 6000 Hours of Operation	87
TROUBLESHOOTING.....	89
TROUBLESHOOTING CHART	90
TROUBLESHOOTING INFORMATION	92
TROUBLESHOOTING OF ELECTRONIC CONTROL SYSTEM.....	93
Fault Detection Capability.....	93
SMARTASSIST-DIRECT (SA-D).....	94
TROUBLESHOOTING FOR ELECTRONIC CONTROL SYSTEM ...	96

TABLE OF CONTENTS

LONG-TERM STORAGE	97
BEFORE YOU PLACE THE ENGINE IN LONG-TERM STORAGE.....	98
RETURNING THE ENGINE TO SERVICE	99
SPECIFICATIONS	101
GENERAL	101
Engine General Specifications	102
PRINCIPAL ENGINE SPECIFICATIONS	103

YANMAR WARRANTIES

YANMAR LIMITED WARRANTY

What is Covered by this Warranty?

YANMAR warrants to the original retail purchaser that a new YANMAR TNV common rail series industrial engine will be free from defects in material and/or workmanship for the duration of the warranty period.

Note: YANMAR engines may be equipped with external components including, but not limited to: wiring harnesses, electrical devices, control panels, radiators, air filters, fuel filters, and/or exhaust systems that are supplied and/or installed by manufacturers other than YANMAR. For warranty information on such external components, please contact the machine or component manufacturer directly or see your authorized YANMAR dealer or distributor.

This warranty is provided in lieu of all other warranties, express or implied. YANMAR specifically disclaims any implied warranties of merchantability or fitness for a particular purpose, except where such disclaimer is prohibited by law. If such disclaimer is prohibited by law, then implied warranties shall be limited in duration to the life of the express warranty.

How Long is the Warranty Period?

The YANMAR standard limited warranty period runs for a period of **twenty-four (24) months or two-thousand (2000) engine operation hours**, whichever occurs first. An extended limited warranty of thirty-six (36) months or three thousand (3000) engine operating hours, whichever occurs first, is provided for these specific parts only: the cylinder block, cylinder head, crankshaft forging, connecting rods, flywheel, flywheel housing, camshaft, timing gear, and gear case. The warranty period for both the standard limited warranty and the extended limited warranty (by duration or operation hours) begins on the date of delivery to the original retail purchaser and is valid only until the applicable warranted duration has passed or the operation hours are exceeded, whichever comes first.

YANMAR WARRANTIES

YANMAR limited warranty - continued

What the Engine Owner must Do:

If you believe your YANMAR engine has experienced a failure due to a defect in material and/or workmanship, you must contact an authorized YANMAR industrial engine dealer or distributor within thirty (30) days of discovering the failure. You must provide proof of ownership of the engine, proof of the date of the engine purchase and delivery, and documentation of the engine operation hours. Acceptable forms of proof of delivery date include, but are not limited to: the original warranty registration or sales receipts or other documents maintained in the ordinary course of business by YANMAR dealers and/or distributors, indicating the date of delivery of the YANMAR product to the original retail purchaser. This information is necessary to establish whether the YANMAR product is still within the warranty period. Thus, YANMAR strongly recommends you register your engine as soon as possible after purchase in order to facilitate any future warranty matters.

You are responsible for the transportation of the engine to and from the repair location as designated by YANMAR.

To Locate an Authorized YANMAR Industrial Engine Dealer or Distributor:

You can locate your nearest authorized YANMAR industrial engine dealer or distributor by visiting the YANMAR CO., LTD. website at:

<https://www.yanmar.com/global/> (The English language page will be displayed.)

- “Click” on “Dealer Locator” in the website heading to view the “Dealer Locator” menu.
- Choose the Country from the pull down menu.
- Choose the Product Category from the pull down menu.
- “Click” on “Search” to browse YANMAR dealer or distributor.

You may also contact YANMAR by clicking on “Contact” icon in the website heading and typing in your question or comment.

What YANMAR will Do:

YANMAR warrants to the original retail purchaser of a new YANMAR engine that YANMAR will make such repairs and/or replacements at YANMAR’s option, of any part(s) of the YANMAR product covered by this warranty found to be defective in material and/or workmanship. Such repairs and/or replacements will be made at a location designated by YANMAR at no cost to the purchaser for parts or labor.

YANMAR limited warranty - continued**What is not Covered by this Warranty?**

This warranty does not cover parts affected by or damaged by any reason other than defective materials or workmanship, including, but not limited to, accident, misuse, abuse, "Acts of God," neglect, improper installation, improper maintenance, improper storage, the use of unsuitable attachments or parts, the use of contaminated fuels, the use of diesel fuels, engine lubricating oil, or engine coolant other than those recommended in your YANMAR Operation Manual, unauthorized alterations or modifications, ordinary wear and tear, and rust or corrosion. This warranty does not cover the cost of parts and/or labor required to perform normal/scheduled maintenance on your YANMAR engine. This warranty does not cover consumable parts such as, but not limited to, filters, belts, hoses, diesel fuels, engine lubricating oil and cleaning fluids. This warranty does not cover the cost of shipping the product to or from the warranty repair facility.

Warranty Limitations:

The foregoing is YANMAR's only obligation to you and your exclusive remedy for breach of warranty. Failure to follow the requirements for submitting a claim under this warranty may result in a waiver of all claims for damages and other relief. **In no event shall YANMAR or any authorized industrial engine dealer or distributor be liable for incidental, special or consequential damages.** Such consequential damages may include, but not be limited to, loss of revenue, loan payments, cost of rental of substitute equipment, insurance coverage, storage, lodging, transportation, fuel, mileage, and telephone costs. The limitations in this warranty apply regardless of whether your claims are based on breach of contract, tort (including negligence and strict liability) or any other theory. Any action arising hereunder must be brought within one (1) year after the cause of action accrues or it shall be barred. Some states and countries do not allow certain limitations on warranties or for breach of warranties. **This warranty gives you specific legal rights, and you may also have other rights which vary from state to state and country to country.** Limitations set forth in this paragraph shall not apply to the extent that they are prohibited by law.

Warranty Modifications:

Except as modified in writing and signed by the parties, this warranty is and shall remain the complete and exclusive agreement between the parties with respect to warranties, superseding all prior agreements, written and oral, and all other communications between the parties relating to warranties. **No person or entity is authorized to give any other warranty or to assume any other obligation on behalf of YANMAR, either orally or in writing.**

Questions:

If you have any questions or concerns regarding this warranty, please call or write to the nearest authorized YANMAR industrial engine dealer or distributor or other authorized facility.

YANMAR WARRANTIES

EMISSION SYSTEM WARRANTY

YANMAR CO., LTD. EMISSION CONTROL SYSTEM WARRANTY - USA ONLY

Your Warranty Rights and Obligations:

The California Air Resources Board (CARB), the United State Environmental Protection Agency (EPA) and YANMAR CO., LTD. hereafter referred to as YANMAR, are pleased to explain the **emission control system warranty** on your 2016, 2017, or 2018 model year industrial compression-ignition engine.

California-certified, new off-road compression-ignition engines must be designed, built and equipped to meet the State's stringent anti-smog standards. In the remaining forty nine (49) states, new non-road compression-ignition engines must be designed, built and equipped to meet the United States EPA emissions standards. YANMAR must warrant the emission control system on your engine for the periods of time listed below provided there has been no abuse, neglect or improper maintenance of your engine.

Your emission control system may include parts such as the fuel injection system, the air induction system, the electronic control system, EGR (Exhaust Gas Recirculation) system and the diesel particulate filter system. Also included may be hoses, belts, connectors and other emission-related assemblies.

Where a warrantable condition exists, YANMAR will repair your off-road compression-ignition engine at no charge to you including diagnosis, parts and labor.

Manufacturer's Warranty Period:

2016, 2017, or 2018 model year off-road compression-ignition engines are warranted for the periods listed below. If any emission-related part on your engine is found to be defective during the applicable warranty period, the part will be repaired or replaced by YANMAR.

If your engine is certified as	And its maximum power is	And its rated speed is	Then its warranty period is
Variable speed or constant speed	kW < 19	Any speed	1,500 hours or two (2) years whichever comes first. In the absence of a device to measure the hours of use, the engine has a warranty period of two (2) years.
Constant speed	19 ≤ kW < 37	3,000 rpm or higher	1,500 hours or two (2) years whichever comes first. In the absence of a device to measure the hours of use, the engine has a warranty period of two (2) years.
Constant speed	19 ≤ kW < 37	Less than 3,000 rpm	3,000 hours or five (5) years whichever comes first. In the absence of a device to measure the hours of use, the engine has a warranty period of five (5) years.
Variable speed	19 ≤ kW < 37	Any speed	3,000 hours or five (5) years whichever comes first. In the absence of a device to measure the hours of use, the engine has a warranty period of five (5) years.
Variable speed or constant speed	kW ≥ 37	Any speed	3,000 hours or five (5) years whichever comes first. In the absence of a device to measure the hours of use, the engine has a warranty period of five (5) years.

Emission control system warranty - USA only - continued

Warranty Coverage:

This warranty is transferable to each subsequent purchaser for the duration of the warranty period. YANMAR recommends that repair or replacement of any warranted part will be performed at an authorized YANMAR dealer.

Warranted parts not scheduled for replacement as required maintenance in the owner's manual shall be warranted for the warranty period. Warranted parts scheduled for replacement as required maintenance in the owner's manual are warranted for the period of time prior to the first scheduled replacement. Any warranted parts scheduled for replacement as required maintenance that are repaired or replaced under warranty shall be warranted for the remaining period of time prior to the first scheduled replacement. Any part not scheduled for replacement that is repaired or replaced under warranty shall be warranted for the remaining warranty period.

During the warranty period, YANMAR is liable for damages to other engine components caused by the failure of any warranted part during the warranty period.

Any replacement part which is functionally identical to the original equipment part in all respects may be used in the maintenance or repair of your engine, and shall not reduce YANMAR's warranty obligations. Add-on or modified parts that are not exempted may not be used. The use of any non-exempted add-on or modified parts shall be grounds for disallowing a warranty.

Warranted Parts:

This warranty covers engine components that are a part of the emission control system of the engine as delivered by YANMAR to the original retail purchaser. Such components may include the following:

- (A) Fuel injection system (including Altitude compensation system)
- (B) Cold start enrichment system
- (C) Intake manifold and Air intake throttle valve
- (D) Turbocharger systems
- (E) Exhaust manifold and exhaust throttle valve
- (F) Positive crankcase ventilation system
- (G) Charge Air Cooling systems (only 3TNV86CHT, 4TNV86CHT, 4TNV94CHT)
- (H) Exhaust Gas Recirculation (EGR) systems
- (I) Exhaust gas after treatment (diesel particulate filter system)
- (J) Electronic Control units, sensors, solenoids and wiring harnesses used in above systems
- (K) Hoses, belts, connectors and assemblies used in above systems
- (L) Emission Control Information Labels

Since emissions related parts may vary slightly between models, certain models may not contain all of these parts and other models may contain the functional equivalents.

YANMAR WARRANTIES

Emission control system warranty - USA only - continued

Exclusions:

Failures other than those arising from defects in material or workmanship are not covered by this warranty. The warranty does not extend to the following: malfunctions caused by abuse, misuse, improper adjustment, modification, alteration, tampering, disconnection, improper or inadequate maintenance, or use of non-recommended fuels and lubricating oils; accident-caused damage and replacement of expendable items made in connection with scheduled maintenance. YANMAR disclaims any responsibility for incidental or consequential such as loss of time, inconvenience, loss of use of equipment/engine or commercial loss.

Owner's Warranty Responsibilities:

As the off-road compression-ignition engine owner, you are responsible for the performance of the required maintenance listed in your owner's manual. YANMAR recommends that you retain all documentation, including receipts, covering maintenance on your off-road compression-ignition engine, but YANMAR cannot deny warranty solely for the lack of receipts, or for your failure to ensure the performance of all scheduled maintenance.

YANMAR may deny your warranty coverage if your off-road compression-ignition engine or a part has failed due to abuse, neglect, improper maintenance or unapproved modifications.

Your engine is designed to operate on diesel fuel only. Use of any other fuel may result in your engine no longer operating in compliance with CARB and EPA emissions requirements.

You are responsible for initiating the warranty process. You are responsible for presenting your engine to an authorized YANMAR dealer or distributor as soon as a problem exists. The warranty repairs should be completed by the dealer as expeditiously as possible. If you have any questions regarding your warranty rights and responsibilities, or would like information on the nearest YANMAR dealer or authorized service center, you should contact YANMAR America Corporation.

Website: <https://www.yanmar.com>

E-mail: CS_support@yanmar.com

Toll free telephone number: 1-800-872-2867, 1-855-416-7091

What the Emergency Stationary Type Engine Owner must Do:

The engines for emergency stationary type generators certified by Federal Law (40 CFR Part60) are limited to emergency use only, and the operation for maintenance checks and verification test for functions is required. The total operating hours for maintenance and verification test for functions should not exceed 100 hours per year. However, there is no limitation on the operating hours for emergency use. Keep a log of the number of hours the engine is operated for both emergency use and non-emergency use. Also, note the reason for the operation.

SAFETY

SAFETY STATEMENTS

YANMAR is concerned for your safety and your machine's condition. Safety statements are one of the primary ways to call your attention to the potential hazards associated with YANMAR TNV engine operation. Follow the precautions listed throughout the manual before operation, during operation and during periodic maintenance procedures for your safety, the safety of others and to protect the performance of your engine. Keep the labels from becoming dirty or torn and replace them if they are lost or damaged. Also, if you need to replace a part that has a label attached to it, make sure you order the new part and label at the same time.



This safety alert symbol appears with most safety statements. It means attention, become alert, your safety is involved! Please read and abide by the message that follows the safety alert symbol.

DANGER

DANGER indicates a hazardous situation which, if not avoided, *will* result in death or serious injury.

WARNING

WARNING indicates a hazardous situation which, if not avoided, *could* result in death or serious injury.

CAUTION

CAUTION indicates a hazardous situation which, if not avoided, *could* result in minor or moderate injury.

NOTICE

NOTICE indicates a situation which can cause damage to the machine, personal property and/or the environment or cause the equipment to operate improperly.

SAFETY PRECAUTIONS

Before You Operate

NOTICE



- Never permit anyone to operate the engine or driven machine without proper training.

- Read and understand this Operation Manual before you operate or service the machine to ensure that you follow safe operating practices and maintenance procedures.
- Machine safety signs and labels are additional reminders for safe operating and maintenance techniques.
- See your authorized YANMAR industrial engine dealer or distributor for additional training.

During Operation and Maintenance

⚠ DANGER

High Pressure Hazard!



- This engine uses a high pressure common rail system. For disassembly of the high pressure parts (e.g. the high pressure fuel pipe) in particular, be sure to wait approximately 10 to 15 minutes before performing disassembly.
- Do not loosen the high-pressure fuel injection lines while the engine is running, even in low idle. This is dangerous because fuel under high pressure will blow out.
- Failure to comply will result in death or serious injury.

⚠ DANGER

Scald Hazard!



- Never remove the radiator cap if the engine is hot. Steam and hot engine coolant will spurt out and seriously burn you. Allow the engine to cool down before you attempt to remove the radiator cap.
- Tighten the radiator cap securely after you check the radiator. Steam can spurt out during engine operation if the cap is loose.
- Always check the level of the engine coolant by observing the reserve tank.
- Failure to comply will result in death or serious injury.

Explosion Hazard!



- Keep the area around the battery well-ventilated. While the engine is running or the battery is charging, hydrogen gas is produced which can be easily ignited.
- Keep sparks, open flame and any other form of ignition away while the engine is running or battery is charging.
- Never short out the battery terminals, including when checking the remaining battery charge. This will result in a spark and may cause an explosion or fire. Use a hydrometer to check the remaining battery charge.
- If the electrolyte is frozen, slowly warm the battery before you recharge it.
- Failure to comply will result in death or serious injury.

Sudden Movement Hazard!



- Never start the engine by shorting out the starter terminal and the battery terminal (Jump-start). The machine may move suddenly if the machine safety circuit is released, but the gear is still engaged.
- Failure to comply will result in death or serious injury.

⚠ DANGER**Fire and Explosion Hazard!**

- Diesel fuel is extremely flammable and explosive under certain conditions.

- When you remove any fuel system component to perform maintenance (such as changing the fuel filter) place an approved container under the opening to catch the fuel.
- Never use a shop rag to catch the fuel. Vapors from the rag are flammable and explosive.
- Wipe up any spills immediately.
- Wear eye protection. The fuel system is under pressure and fuel could spray out when you remove any fuel system component.
- Only use the key switch to start the engine.
- Never jump-start the engine. Sparks caused by shorting the battery to the starter terminals may cause a fire or explosion.
- Only fill the fuel tank with diesel fuel. Filling the fuel tank with gasoline may result in a fire and will damage the engine.
- Never refuel with the engine running.
- Keep sparks, open flames or any other form of ignition (match, cigarette, static electric source) well away when refueling.
- Never overfill the fuel tank.
- Fill the fuel tank. Store any containers containing fuel in a well-ventilated area, away from any combustibles or sources of ignition.
- Be sure to place the diesel fuel container on the ground when transferring the diesel fuel from the pump to the container. Hold the hose nozzle firmly against the side of the container while filling it. This prevents static electricity buildup which could cause sparks and ignite fuel vapors.

⚠ DANGER

(Continued)

- Never place diesel fuel or other flammable material such as oil, hay or dried grass close to the engine during engine operation or shortly after shutdown.
- Before you operate the engine, check for fuel leaks. Replace rubberized fuel hoses every two years or every 2000 hours of engine operation, whichever comes first, even if the engine has been out of service. Rubberized fuel lines tend to dry out and become brittle after two years or 2000 hours of engine operation, whichever comes first.
- Never remove the fuel cap with the engine running.
- Never use diesel fuel as a cleaning agent.
- Failure to comply will result in death or serious injury.

Crush Hazard!

- When you need to transport an engine for repair, have a helper assist you to attach it to a hoist and load it on a truck.
- Never stand under a hoisted engine. If the hoist mechanism fails, the engine will fall on you, causing death or serious injury.
- Failure to comply will result in death or serious injury.

⚠ WARNING

Sever Hazard!



- Keep hands and other body parts away from moving/rotating parts such as the cooling fan, flywheel or PTO shaft.

- Wear tight-fitting clothing and keep your hair short or tie it back while the engine is running.
- Remove all jewelry before you operate or service the machine.
- Never start the engine in gear. Sudden movement of the engine and/or machine could cause death or serious personal injury.
- Never operate the engine without the guards in place.
- Before you start the engine make sure that all bystanders are clear of the area.
- Keep children and pets away while the engine is operating.
- Check before starting the engine that any tools or shop rags used during maintenance have been removed from the area.
- Failure to comply could result in death or serious injury.

Exhaust Hazard!



- Never operate the engine in an enclosed area such as a garage, tunnel, underground room, manhole or ship's hold without proper ventilation.
- Never block windows, vents, or other means of ventilation if the engine is operating in an enclosed area. All internal combustion engines create carbon monoxide gas during operation. Accumulation of this gas within an enclosure could cause illness or even death.
- Make sure that all connections are tightened to specifications after repair is made to the exhaust system.
- Failure to comply could result in death or serious injury.

⚠ WARNING

Alcohol and Drug Hazard!



- Never operate the engine while you are under the influence of alcohol or drugs.

- Never operate the engine when you are feeling ill.
- Failure to comply could result in death or serious injury.

Exposure Hazard!



- Wear personal protective equipment such as gloves, work shoes, eye and hearing protection as required by the task at hand.
- Never wear jewelry, unbuttoned cuffs, ties or loose-fitting clothing when you are working near moving/rotating parts such as the cooling fan, flywheel or PTO shaft.
- Always tie back long hair when you are working near moving/rotating parts such as a cooling fan, flywheel, or PTO shaft.
- Never operate the engine while wearing a headset to listen to music or radio because it will be difficult to hear the alert signals.
- Failure to comply could result in death or serious injury.

⚠ WARNING**Burn Hazard!**

- If you drain the engine lubricating oil while it is still hot, stay clear of the hot engine lubricating oil to avoid being burned. Always wear eye protection when you handle the engine coolant.
- If you must drain the engine coolant while it is still hot, stay clear of the hot engine coolant to avoid being burned.
- Keep your hands and other body parts away from hot engine surfaces such as the muffler, exhaust pipe, turbocharger (if equipped) and engine block during operation and shortly after you shut the engine down. These surfaces are extremely hot while the engine is operating and could seriously burn you.
- Failure to comply could result in death or serious injury.

Burn Hazard!

- Batteries contain sulfuric acid. Never allow battery fluid to come in contact with clothing, skin or eyes. Severe burns could result. Always wear safety goggles and protective clothing when servicing the battery. If battery fluid contacts the eyes and/or skin, immediately flush the affected area with a large amount of clean water and obtain prompt medical treatment.
- Failure to comply could result in death or serious injury.

⚠ WARNING**High-Pressure Hazard!**

- While the engine is running or right after the engine has stopped, there is still high-pressure fuel left in the fuel piping system. When you need to disassemble the fuel system, wait for 10 to 15 minutes after stopping the engine.
- If fuel is spraying out or leaking from broken fuel system such as high-pressure fuel injection lines, it may be in high-pressure. Avoid skin contact. High-pressure fuel can penetrate your skin and result in serious injury. If you are exposed to high-pressure fuel spray, obtain prompt medical treatment.
- Disassembling or repairing the fuel system shall be done by professionals such as the authorized YANMAR distributor or dealer.
- Failure to comply could result in death or serious injury.

Shock Hazard!

- Turn off the battery switch (if equipped) or disconnect the negative battery cable before servicing the electrical system.
- Check the electrical harnesses for cracks, abrasions, and damaged or corroded connectors. Always keep the connectors and terminals clean.
- Failure to comply could result in death or serious injury.

⚠ WARNING

Entanglement Hazard!



- Stop the engine before you begin to service it.

- Never leave the key in the key switch when you are servicing the engine. Someone may accidentally start the engine and not realize you are servicing it. This could result in a serious injury.
- If you must service the engine while it is operating, remove all jewelry, tie back long hair, and keep your hands, other body parts and clothing away from moving/rotating parts.
- Failure to comply could result in death or serious injury.

Sudden Movement Hazard!

- Before engaging the transmission or PTO, warm up the engine for at least 5 minutes and then set the speed back to normal. Engaging the transmission or PTO at an elevated engine speed could result in unexpected movement of the equipment.
- Failure to comply could result in death or serious injury.

⚠ WARNING

Precaution regarding the ECU (Engine Controller)

- Never use the ECU for purposes that are not intended by YANMAR; such as using unauthorized ECU, writing unauthorized data to ECU, leaving it broken, or removing sensors and actuators. Doing so could result in the violation of emission control regulations and will void the product warranty.
 - Improper use or misuse of the ECU may result in death or serious injury due to an abrupt and unexpected increase in engine speed.
-
- Be sure to use the ECU in conjunction with the engines whose models or serial numbers are specified by YANMAR. Other ECU/engine combinations than specified will void the engine warranty.
 - Improper use or misuse of the ECU may result in death or serious injury due to an abrupt and unexpected increase in engine speed.
-
- When replacing the fuel injector, you need to rewrite the fuel injection quantity adjustment data in the ECU. You will need YANMAR's genuine SMARTASSIST-DIRECT (SA-D) for rewriting the data. Always contact your authorized YANMAR dealer who can handle SMARTASSIST-DIRECT (SA-D). ECU that does not have the proper fuel injection quantity adjustment data written will void the engine warranty.
 - Improper use or misuse of the ECU may result in death or serious injury due to an abrupt and unexpected increase in engine speed.
-
- When replacing the ECU, it is necessary to transfer the data from the old ECU to the new ECU using SMARTASSIST-DIRECT (SA-D). Contact your authorized YANMAR dealer who can handle SMARTASSIST-DIRECT (SA-D). If the data is not correctly transferred to the new ECU, the engine performance can not be ensured.
 - Improper use or misuse of the ECU may result in death or serious injury due to an abrupt and unexpected increase in engine speed.

⚠ CAUTION**DPF Regeneration**

During reset regeneration, post-injection is used and fuel is burned directly inside the DPF (burned by chemical reaction inside the DOC). Through this heat, regeneration occurs inside the SF, but the combustion increases the temperature of the exhaust gas to close to 600 °C (1112 °F). Stay away from the exhaust gas. Extremely hot exhaust gas may burn you. Be careful that neither people nor flammable materials are near the exhaust gas outlet. Never operate the engine in an enclosed area without proper ventilation.

Observe the following conditions when performing stationary regeneration.

- Never operate the engine in an enclosed area. Accumulation of gas may cause carbon monoxide poisoning.
- Regeneration causes the exhaust gas temperature to increase. To prevent fire, make sure that there are no flammable materials around the exhaust gas outlet.
- Never touch the exhaust pipe. The temperature of the exhaust gas can be extremely high. Never stand near or around the exhaust gas outlet.

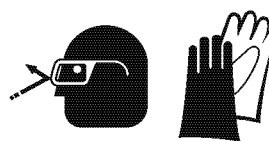
⚠ CAUTION**Engine Coolant Hazard!**

- Wear eye protection and rubber gloves when you handle long life or extended life engine coolant. If contact with the eyes or skin should occur, flush eyes and wash immediately with clean water.

- Failure to comply may result in minor or moderate injury.

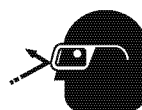
Flying Object Hazard!

- Always wear eye protection when servicing the engine and when using compressed air or high-pressure water. Dust, flying debris, compressed air, pressurized water or steam may injure your eyes.

- Failure to comply may result in minor or moderate injury.

NOTICE

Diesel Fuel

- Poor quality fuel can reduce engine performance and cause damage. Only use diesel fuels recommended by YANMAR for the best engine performance. The recommended fuel complies with the U.S. EPA and ARB protection guidelines.
- The common rail system installed as this engine's fuel injection device is very high in pressure and sprays fuel into the cylinder. If any impurities or water mixes into the fuel, the sliding parts of the fuel system causes friction and may degrade the engine's exhaust gas property durability. Only use clean diesel fuel.
- Keep the fuel tank and fuel-handling equipment clean at all times. Be careful not to let any contaminants or even dust from the outside into the filler port when supplying fuel.
- Never remove the primary strainer (if equipped) from the fuel tank filler port. If removed, dirt and debris could get into the fuel system causing it to clog.
- Be sure to use YANMAR genuine filter for replacing the fuel filter or the water separator filter.

Engine Lubricating Oil

- Only use the engine lubricating oil specified. Other oils may affect warranty coverage, cause internal engine components to seize and/or shorten engine life.
- Prevent dirt and debris from contaminating the engine lubricating oil. Carefully clean the oil cap/dipstick and the surrounding area before you remove the cap.
- Never mix different types of engine lubricating oil. This may adversely affect the lubricating properties of the engine oil.
- Always keep the oil level between the upper and lower lines on the oil cap/dipstick.
- Never overfill the engine with engine lubricating oil. Overfilling may result in white exhaust smoke, engine overspeed or internal damage.
- Be sure to use YANMAR genuine filter for replacing the engine lubricating oil filter.

NOTICE

Engine Coolant

- Only use the engine coolant specified. Other engine coolants may affect warranty coverage, cause an internal buildup of rust and scale and/or shorten engine life.
- Prevent dirt and debris from contaminating the engine coolant. Carefully clean the radiator cap and the surrounding area before you remove the cap.
- Never mix different types of engine coolants. This may adversely affect the properties of the engine coolant.

Inspecting and Starting

- If any problem is noted during the visual check, the necessary corrective action should be taken before you operate the engine.
- This is an electric feed pump. When you prime the fuel system, turn the key switch to the ON position for 10 to 15 seconds. Air inside the fuel will bleed automatically.

If any indicator fails to illuminate when the key switch is in the ON position, see your authorized YANMAR industrial engine dealer or distributor for service before operating the engine.

Never hold the key in the START position for longer than 15 seconds.
Take a pause of at least 30 seconds until the restart.
The starter motor may overheat and cause damage.

If the engine fails to start:
Wait until the engine comes to a complete stop before you attempt to start it again. Engaging the starter while the engine is still rotating will result in damage to the starter and flywheel.

Never use an engine starting aid such as ether.
Engine damage will result.

Never engage the starter motor while the engine is running. This may damage the starter motor pinion and/or ring gear.

NOTICE**Engine Break-in Period**

New engine break-in:

- On the initial engine start-up, allow the engine to idle for approximately 15 minutes while you check for proper engine lubricating oil pressure, diesel fuel leaks, engine lubricating oil leaks, coolant leaks, and for proper operation of the indicators and/or gauges.
- During the first hour of operation, vary the engine speed and the load on the engine. Short periods of maximum engine speed and load are desirable. Avoid prolonged operation at minimum or maximum engine speeds and loads for the next four to five hours.
- During the break-in period, carefully observe the engine lubricating oil pressure and engine coolant temperature.
- During the break-in period, check the engine lubricating oil and coolant levels frequently.

Make sure the engine is installed on a level surface. If a continuously running engine is installed at an angle greater than (30°) in any direction or if an engine runs for short periods of time (less than three minutes) at an angle greater than (35°) in any direction, engine lubricating oil may enter the combustion chamber causing excessive engine speed and white exhaust smoke. This may cause serious engine damage.

Alarm System

If there is a problem with the engine and/or its control components, the engine failure lamp comes on and indicates the status. If the engine failure lamp illuminates during engine operation, stop the engine immediately. Do not keep running the engine while the engine failure lamp is on. It will not only void the engine warranty, but could result in a serious malfunction of or damage to the engine. Determine the cause and repair the problem before you continue to operate the engine.

NOTICE

The illustrations and descriptions of optional equipment in this manual, such as the operator's console, are for a typical engine installation. Refer to the documentation supplied by the optional equipment manufacturer for specific operation and maintenance instructions.

Environment Conditions for Operation

Observe the following environmental operating conditions to maintain engine performance and avoid premature engine wear:

- Avoid operating in extremely dusty conditions.
- Avoid operating in the presence of chemical gases or fumes.
- Avoid operating in a corrosive atmosphere such as salt water spray.
- Never expose the engine to the rain.
- If the ambient temperature exceeds +45 °C (+113 °F) or falls below -15 °C (+5 °F), there are possibilities of:
 - If the ambient temperature exceeds +45 °C (+113 °F), engine lubricating oil degrades due to the overheating of the engine.
 - If the ambient temperature falls below -15 °C (+5 °F), parts degrade and shortens its life due to the hardening of the rubber parts.

Contact your authorized YANMAR dealer or distributor when using in such temperature range.
- Further, for engines with turbochargers, be aware that leaving them idling or working in low load in an environment with ambient temperature below -15 °C (+5 °F) may freeze the intake pipe. If this continues, load-operate the engine every three hours to prevent freezing.
- Contact your authorized YANMAR industrial engine dealer or distributor if the engine will be operated at high altitude. High altitude reduces engine power, de-stabilizes operation and generates exhaust gas that exceeds the specification amount in design.

NOTICE

- When the engine is operated in dusty conditions, clean the air cleaner element more frequently.
- Never operate the engine with the air cleaner element(s) removed. This may allow foreign material to enter the engine and damage it.
- Be sure to use designated element when replacing the air cleaner element.

The maximum air intake restriction, in terms of differential pressure measurement, must not exceed 0.90 psi (6.23 kPa; 635 mmAq). Clean or replace the air cleaner element if the air intake restriction exceeds the above mentioned value.

Engine Stop

For maximum engine life, YANMAR recommends that when shutting the engine down, you allow the engine to idle, without load, for five minutes. This will allow the engine components that operate at high temperatures, such as the turbocharger (if equipped) and exhaust system, to cool slightly before the engine itself is shut down.

Battery and Electrical Equipment

Always keep the battery in a best charged state. Electronic controlled engines may not be able to start.

Use a specialized battery charger to recharge a battery with a voltage of 8 volts or less. Booster starting a battery with a voltage of 8 volts or less will generate an abnormally high voltage and destroy electrical equipment.

When unavoidably using a rapid charger to recharge, do not insert and turn the starter key to ON position while the battery is being charged. Avoid using a charger equipped with a boost function (cell start support) to start the engine. The ECU may be damaged by applied excessive voltage.

NOTICE

Removing the battery cables or the battery while the engine is operating may cause damage to the current limiter depending on the electrical equipment being used. This situation could cause loss of control of output voltage. The continuous high voltage of 23 - 24 volts (for 5000 min⁻¹ (rpm) dynamo) will damage the current limiter and other electrical equipment.

Reversing the battery cable connections at the battery or on the engine will destroy the SCR diode in the current limiter. This will cause the charging system to malfunction and may cause damage to the electrical harnesses.

Do not remove the positive (+) battery cable from alternator terminal B while the engine is operating. Damage to the alternator will result.

Do not turn the battery switch OFF (if equipped) while the engine is operating. Damage to the alternator will result.

Do not reverse the positive (+) and negative (-) ends of the battery cable. The alternator diode and stator coil will be damaged.

When the battery indicator goes out, it should not come on again. The battery indicator only comes on during operation if the alternator fails. However, if an LED is used in the battery indicator, the LED will shine faintly during normal operation.

Using a non-specified V-belt will cause inadequate charging and shorten the belt life. Use the specified belt.

Agricultural or other chemicals, especially those with a high sulfur content, can adhere to the IC regulator. This will corrode the conductor and result in battery over-charging (boiling) and charging malfunctions. Consult YANMAR before using the equipment in such an environment or the warranty is voided.

NOTICE**ECU (Engine Controller)**

- Do not plug or unplug the ECU for a period of at least 60 seconds after power to the unit has been turned on or off.
- Do not touch connector pins of the ECU with bare hands. Doing so may result in corrosion of the connector pins and/or damage to the internal circuits of the ECU due to static electricity.
- Do not force a measuring probe into the female coupler. Doing so may cause contact failure of the connector pins, resulting in malfunction of the ECU.
- Take care to prevent water from entering the couplers when plugging or unplugging the connector. Water inside the couplers may cause corrosion, resulting in malfunction of the ECU.
- Avoid plugging/unplugging the connector more than approx. 10 times.
Frequent plugging/unplugging of the connector may cause contact failure of the connector pins, resulting in malfunction of the ECU.
- Do not use the ECU that has ever suffered drop impact.

High-pressure Cleaning

Protect the air cleaner, turbocharger (if equipped) and electric components from damage when you use steam or high-pressure water to clean the engine.

Never use high-pressure water or compressed air at greater than 28 psi (193 kPa; 19686 mmAq) or a wire brush to clean the radiator fins. Radiator fins damage easily.

NOTICE

- Do not use a high-pressure cleaner directly on the alternator. Water will damage the alternator and result in inadequate charging.
- The starter motor is water-proofed according to JIS D 0203, R2 which protects the motor from rain or general cleaning. Do not use high-pressure cleaner or submerge the starter motor in water.
- Avoid using high-pressure cleaner for electronic or electric devices installed in, on or around the engine, including the E-ECU, relays and harness couplers.

Otherwise such devices may suffer malfunction due to water ingress into them.

Periodic Maintenance

Establish a periodic maintenance plan according to the engine application and make sure you perform the required periodic maintenance at intervals indicated. Failure to follow these guidelines will impair the engine's safety and performance characteristics, shorten the engine's life and may affect the warranty coverage on your engine.

Periodic maintenance prevents unexpected downtime, reduces the number of accidents due to poor machine performance and helps extend the life of the engine.

The tightening torque in the *Standard Torque Chart in the Periodic Maintenance Section of this manual* should be applied only to the bolts with a "7" head. (JIS strength classification: 7T)

- Apply 60 % torque to bolts that are not listed.
- Apply 80 % torque when tightened to aluminum alloy.



NOTICE



- Always be environmentally responsible.

- Follow the guidelines of the EPA or other governmental agencies for the proper disposal of hazardous materials such as engine oil, diesel fuel and engine coolant. Consult the local authorities or reclamation facility.
- Never dispose of hazardous materials irresponsibly by dumping them into a sewer, on the ground, or into ground water or waterways.
- Failure to follow these procedures may seriously harm the environment.

-
- Never attempt to modify the engine's design or safety features such as defeating the engine speed limit control.
 - Modifications may impair the engine's safety and performance characteristics and shorten the engine's life. Any alterations to this engine may void its warranty. Be sure to use YANMAR genuine replacement parts.

Operating the Engine or the Machine



- Never permit anyone to operate the engine or driven machine without proper training.

- Read and understand this Operation Manual before you operate or service the machine to ensure that you follow safe operating practices and maintenance procedures.
- Machine safety signs and labels are additional reminders for safe operating and maintenance techniques.

NOTICE

Precautions for Handling Desiccant

Disposal:

This material is disposable as non-flammable.

however, the bag is flammable and if it is necessary, then tear the bag and discard the bag and the contents separately.

It is desirable to bury the contents in the bag under ground.

Dispose in accordance with the disposal standards for industrial waste defined by local laws and regulations.

Handling:

The contents of the bag do not leak out in the normal use.

Take the following emergency measures, however, if the contents leak out.

- If the contents get on the skin, rinse thoroughly with running water.
- If the contents get in the eyes, rinse thoroughly with water. Consult with doctors when any abnormalities are found.
- If the contents get in the mouth, rinse thoroughly with water. Drink water to dilute if the content is swallowed, though a small amount is harmless. Consult with doctors when any abnormalities are found.

Characteristics of materials:

- | | |
|---|--------------|
| • Calcium Chloride (CaCl ₂) | Approx. 57 % |
| • Grain Polysaccharide | Approx. 28 % |
| • Grain Skins | Approx. 9 % |
| • Ethylene Polymer (Bag) | Approx. 5 % |

Hazard information:

- | | |
|------------------|-------------|
| • Explosiveness | None |
| • Inflammability | Inflammable |
| • Combustibility | None |
| • Oxidation | None |

PRODUCT OVERVIEW

YANMAR TNV ENGINE FEATURES AND APPLICATIONS

YANMAR's series of TNV engines are environmentally friendly and are designed to:

- Lower the amount of exhaust gas emissions.
- Reduce engine noise and vibration.
- Be economical to run because diesel fuel and engine oil consumption are reduced.
- Be easy to operate due to the minimum amount of required maintenance and their compact design.
- Be durable and reliable due in part to the newly designed fuel injection valve and fuel injection pump.

YANMAR TNV engines are designed to supply power to a wide variety of driven machines including:

- Construction
- Agriculture
- Power generation

We are sure that you will agree these features provide excellent value in an industrial diesel engine.

These engines are designed to deliver power to driven machines by means of a “direct coupled drive” or “belt drive”. In direct coupled drive engine applications, the engine's flywheel housing or end plate is coupled directly to the driven machine. In belt drive engine applications, a belt drive is used to power the driven machine. If you have applications that require a belt drive and/or front power take-off (PTO), please contact your authorized YANMAR industrial engine dealer or distributor.

The engine is designed for a wide range of applications. Options, such as fuel tank, control panel, indicators, gauges and alarms, are available to customize the application.

Since designing the application and installing the engine require special knowledge and skill, always consult your authorized YANMAR industrial engine dealer or distributor for these services. They will help you:

- Select optional equipment. Optional equipment should be selected to match the work conditions and environment.
- Maximize engine performance with a minimum amount of downtime and safety related incidents by carefully matching the characteristics of the engine with the driven machine.
- Plan for safe fuel piping, exhaust piping, electrical wiring, ventilation and accurate engine installation.
- Design your applications so they meet requirements of the local authorities.

COMPONENT IDENTIFICATION

■ 3TNV88C, 3TNV86CT, 3TNV86CHT, 4TNV88C, 4TNV86CT, 4TNV86CHT

Figure 1 shows the location of main parts on 3TNV88C, 3TNV86CT, 4TNV88C, and 4TNV86CT common rail system engines.

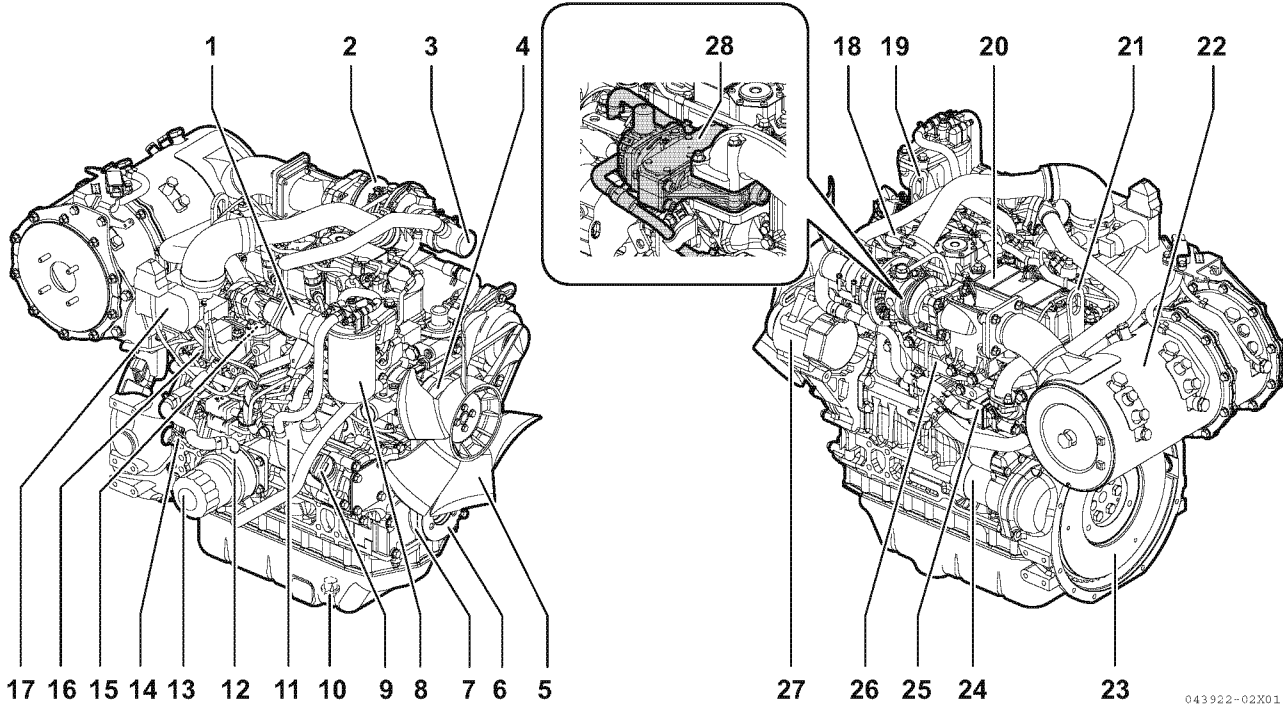

- 1 – EGR valve
- 2 – Turbocharger*1
- 3 – Air intake port (from air cleaner)
- 4 – Engine coolant pump
- 5 – Engine cooling fan
- 6 – Crankshaft V-pulley
- 7 – V-belt
- 8 – Fuel filter
- 9 – Side filler port (engine oil)
- 10 – Drain plug (engine oil)*2
- 11 – Supply pump
- 12 – Engine oil cooler*3
- 13 – Engine oil filter
- 14 – Dipstick (engine oil)

- 15 – Intake manifold
- 16 – Common rail
- 17 – Intake throttle valve
- 18 – Top filler port (engine oil)
- 19 – Lifting eye (engine cooling fan end)
- 20 – Cylinder head cover
- 21 – Lifting eye (flywheel end)
- 22 – Diesel Particulate Filter (DPF)*4
- 23 – Flywheel
- 24 – Starter motor
- 25 – EGR cooler
- 26 – Exhaust manifold
- 27 – Alternator
- 28 – Exhaust throttle*5

Figure 1

*1: Only applies to 3TNV86CT, 3TNV86CHT, 4TNV86CT, 4TNV86CHT.

*2: Engine oil drain plug location may vary based on oil pan options.

*3: This may not be equipped to some of the engines.

*4: DPF locations vary depending on the engine model.

*5: This may be equipped to some of the engines.

■ 4TNV98C, 4TNV98CT

Figure 2 shows the location of main parts on 4TNV98C and 4TNV98CT common rail system engines.

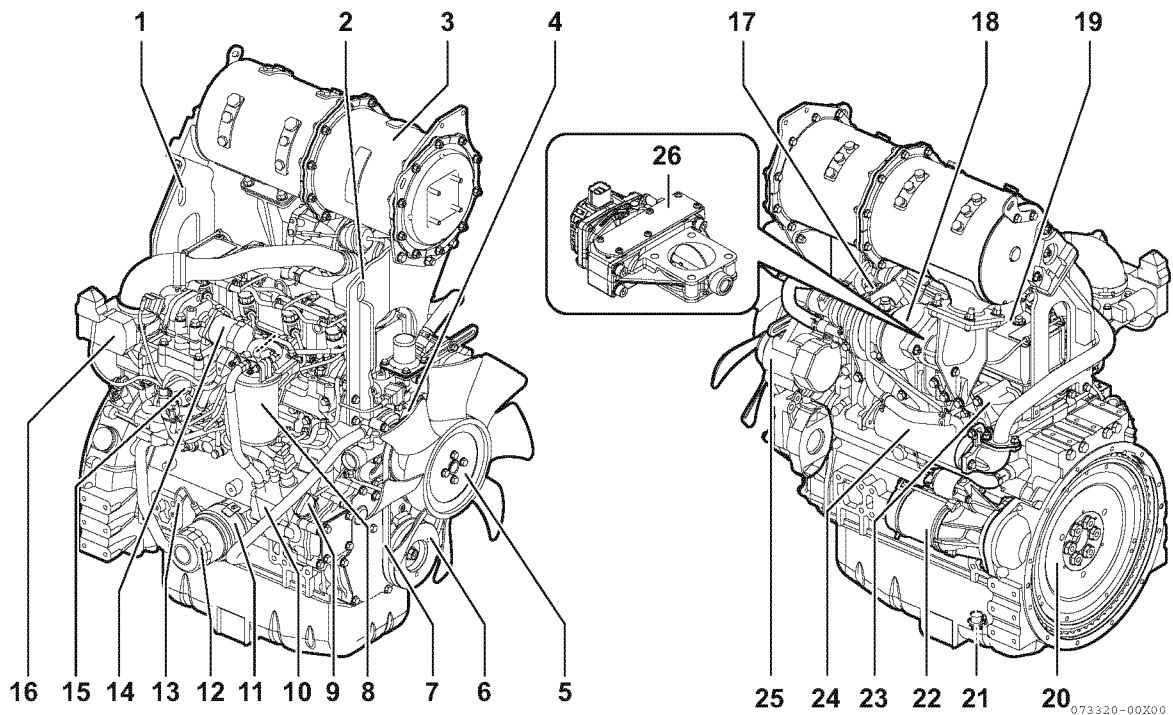

- 1 – Lifting eye (flywheel end)
- 2 – Lifting eye (engine cooling fan end)
- 3 – Diesel Particulate Filter (DPF)*1
- 4 – Engine coolant pump
- 5 – Engine cooling fan
- 6 – Crankshaft V-pulley
- 7 – V-belt
- 8 – Fuel filter
- 9 – Side filler port (engine oil)
- 10 – Supply pump
- 11 – Engine oil cooler
- 12 – Engine oil filter
- 13 – Dipstick (engine oil)

- 14 – EGR valve
- 15 – Common rail
- 16 – Intake throttle valve
- 17 – Top filler port (engine oil)
- 18 – Turbocharger*2
- 19 – Cylinder head cover
- 20 – Flywheel
- 21 – Drain plug (engine oil)*3
- 22 – Starter motor
- 23 – Exhaust manifold
- 24 – EGR cooler
- 25 – Alternator
- 26 – Exhaust throttle*4

Figure 2

*1: DPF locations vary depending on the engine model.
 *2: Only applies to 4TNV98CT.
 *3: Engine oil drain plug location may vary based on oil pan options.
 *4: This may be equipped to some of the engines.

PRODUCT OVERVIEW

■ 4TNV94CHT

Figure 3 shows the location of main parts on 4TNV94CHT common rail system engines.

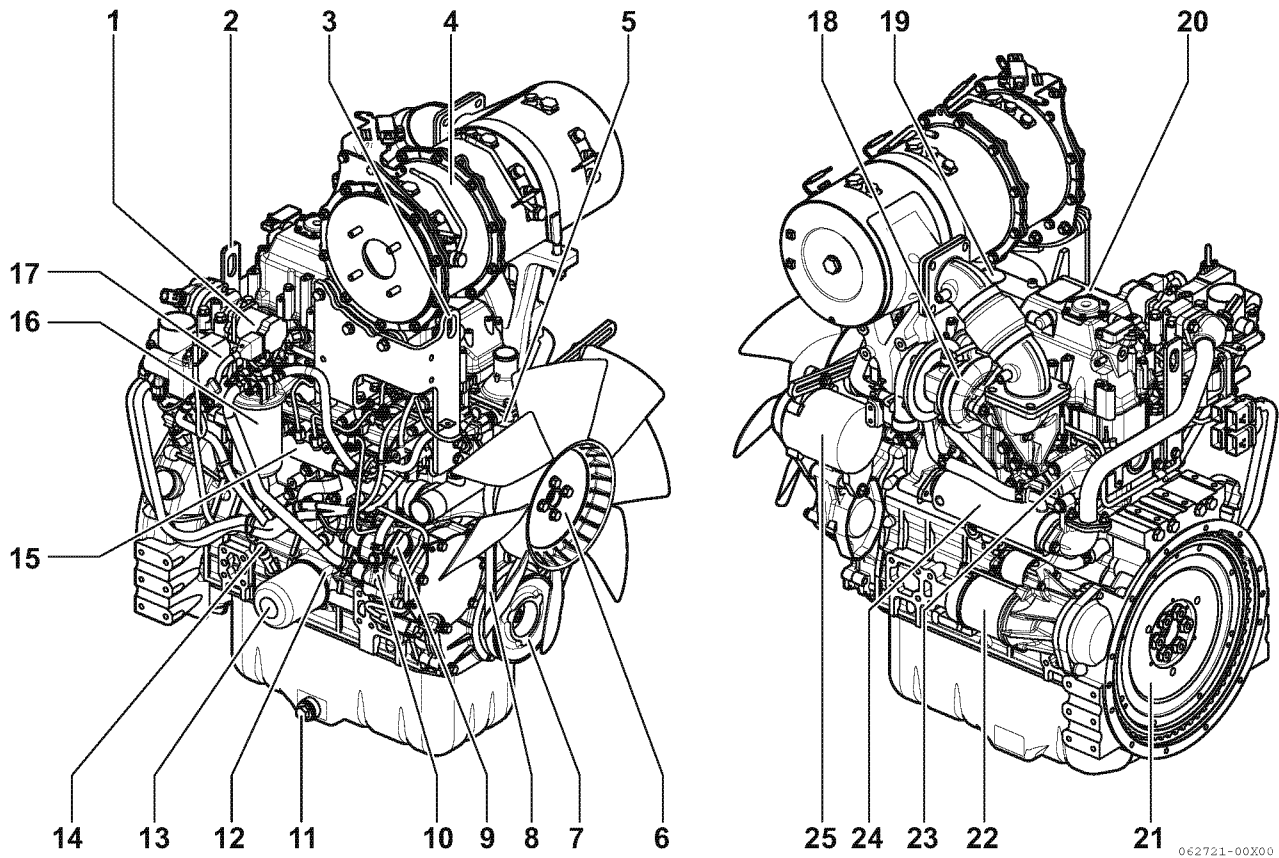

- 1 – EGR valve
- 2 – Lifting eye (flywheel end)
- 3 – Lifting eye (engine cooling fan end)
- 4 – Diesel Particulate Filter (DPF)*2
- 5 – Engine coolant pump
- 6 – Engine cooling fan
- 7 – Crankshaft V-pulley
- 8 – V-belt
- 9 – Side filler port (engine oil)
- 10 – Supply pump
- 11 – Drain plug (engine oil)*1
- 12 – Engine oil cooler
- 13 – Engine oil filter

- 14 – Dipstick (engine oil)
- 15 – Common rail
- 16 – Fuel filter
- 17 – Intake throttle valve
- 18 – Turbocharger
- 19 – Top filler port (engine oil)
- 20 – Cylinder head cover
- 21 – Flywheel
- 22 – Starter motor
- 23 – Exhaust manifold
- 24 – EGR cooler
- 25 – Alternator

Figure 3

*1: Engine oil drain plug location may vary based on oil pan options.

*2: DPF locations vary depending on the engine model.

LOCATION OF LABELS

Figure 4 to Figure 7 shows the location of engine labels and safety labels on YANMAR TNV series engines.

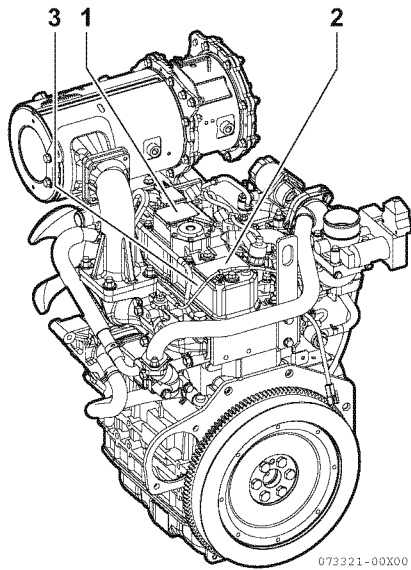

Figure 4

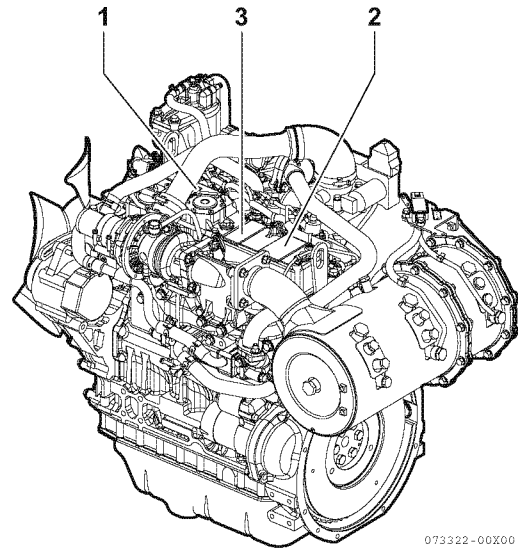

Figure 5

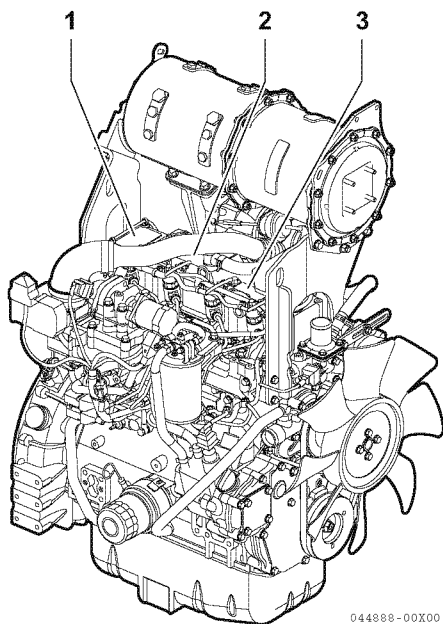

Figure 6

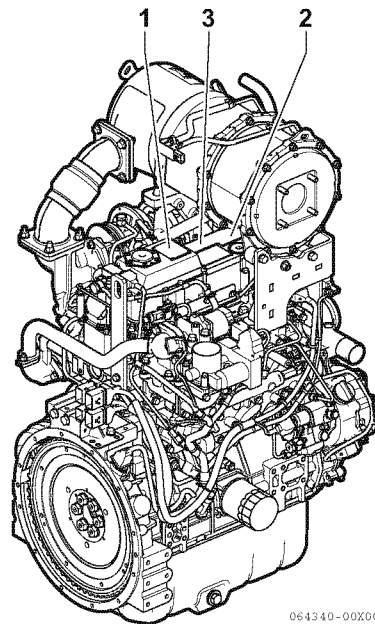
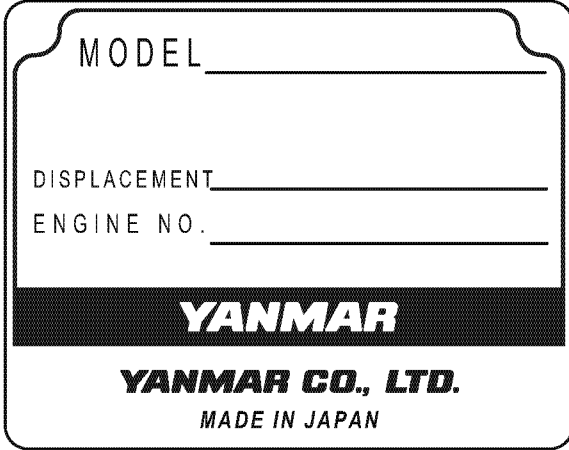

Figure 7

Model	Engine nameplate	EPA/ARB certification label	97/68/EC emission control label
3TNV88C, 3TNV86CT, 3TNV86CHT	On the top of the cylinder head cover (cooling fan end) (1, Figure 4)	On the top of the cylinder head cover (flywheel end) (2, Figure 4)	Side faces of engine cylinder head cover (exhaust side and flywheel side) (3, Figure 4)
4TNV88C, 4TNV86CT, 4TNV86CHT	On the top of the cylinder head cover (cooling fan end) (1, Figure 5)	On the top of the cylinder head cover (flywheel end) (2, Figure 5)	On the top of the cylinder head cover (center) (3, Figure 5)
4TNV98C, 4TNV98CT	On the top of the cylinder head cover (flywheel end) (1, Figure 6)	On the top of the cylinder head cover (center) (2, Figure 6)	On the top of the cylinder head cover (cooling fan end) (3, Figure 6)
4TNV94CHT	On the top of the cylinder head cover (cooling fan end) (1, Figure 7)	On the top of the cylinder head cover (flywheel end) (2, Figure 7)	On the top of the cylinder head cover (center) (3, Figure 7)

PRODUCT OVERVIEW

Engine Nameplate (Typical)



EMISSION CONTROL REGULATIONS

EPA/ARB Regulations - USA Only

YANMAR TNV engines meet Environmental Protection Agency (EPA) (U. S. Federal) emission control standards as well as the California Air Resources Board (ARB, California) regulations. Only engines that conform to ARB regulations can be sold in the State of California.

Refer to the specific EPA/ARB installation (page 69) and maintenance (page 69) in the *Periodic Maintenance Schedule* section of this manual. Also refer to the *Emission System Warranty on page 4*.

EMISSION CONTROL LABELS

Since emission control regulations are being issued on a global basis, it is necessary to identify which regulations a particular engine complies with. We have listed several different types of labels you might find on your engine.

EPA/ARB Labels (Typical)

EPA: United States Environmental Protection Agency

ARB: California Air Resources Board

■ EPA

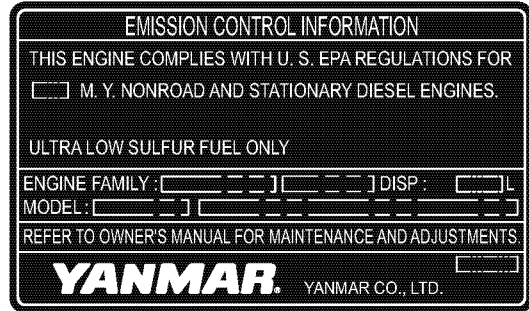

■ EPA and ARB

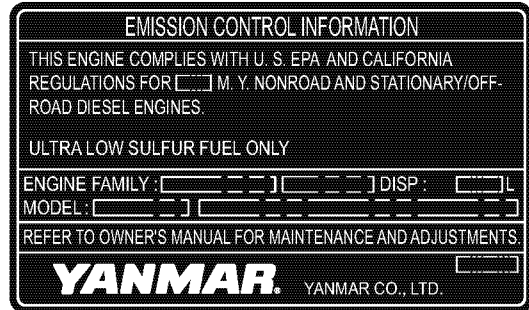

The 97/68/EC Directive Certified Labels

The engines described in this manual have been certified by the 97/68/EC Directive.

To identify the engines that meet this certification, the 97/68/EC emission control label is affixed on the engines.

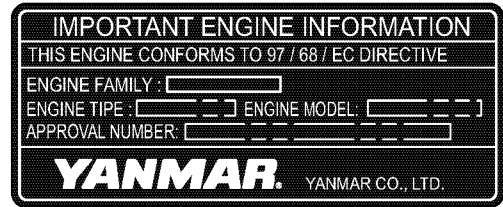

ENGINE FAMILY

The EPA/ARB labels and the 97/68/EC label all have an Engine Family field.

The following is an explanation of the Engine Family designation:

The example of the EPA/ARB label indication is shown below. An indication is different for the 97/68/EC Directive Certified Labels.

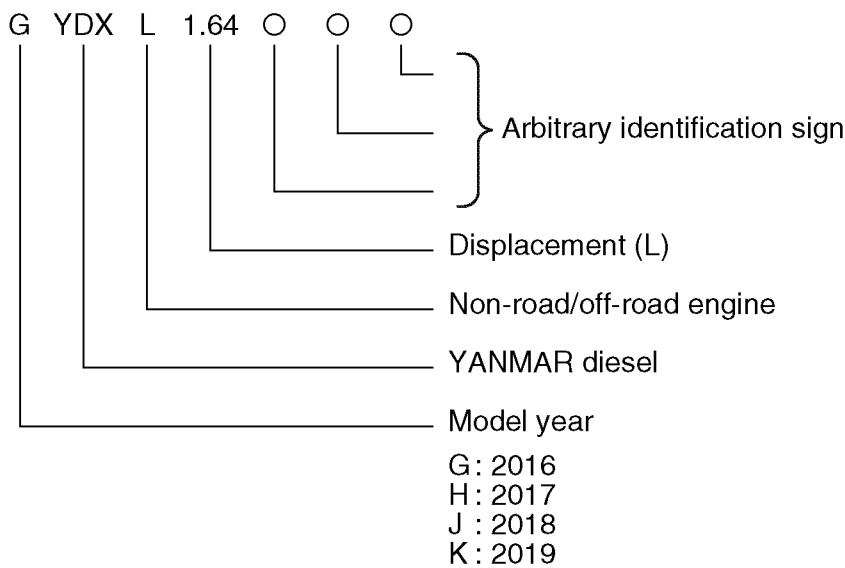

PRODUCT OVERVIEW

FUNCTION OF MAJOR ENGINE COMPONENTS

Components	Functions
Air cleaner	The air cleaner prevents airborne contaminants from entering the engine. Since the air cleaner is application specific, it must be carefully selected by an application engineer. It is not part of the basic engine package as shipped from the YANMAR factory. Periodic replacement of the air cleaner filter element is necessary. <i>See the Periodic Maintenance Schedule on page 70</i> for the replacement frequency.
Alternator	The alternator is driven by a V-belt which is powered by the crankshaft V-pulley. The alternator supplies electricity to the engine systems and charges the battery while the engine is running.
Dipstick (engine lubricating oil)	The engine lubricating oil dipstick is used to determine the amount of engine lubricating oil in the crankcase.
Electric fuel feed pump	The fuel pump force-feeds fuel from the fuel tank to the supply pump. The DI engine uses the electric type, and the solenoid valve runs on 12 V (DC). When sending fuel to the fuel system, by keeping the key of the key switch in the ON position for 10 to 15 seconds, the air inside the fuel is automatically bled.
Engine lubricating oil filter	The engine lubricating oil filter removes contaminants and sediment from the engine lubricating oil. Periodic replacement of the engine lubricating oil filter is necessary. <i>See the Periodic Maintenance Schedule on page 70</i> for the replacement frequency.
Engine lubricating oil cooler	The engine lubricating oil cooler helps to keep the engine lubricating oil cool. The coolant in the cylinder block flows through the adapter at the bottom of the assembly of the lubricating oil filter and circulates through the lubricating oil cooler, and returns to intake port of the engine coolant pump. This may not be equipped to some of the engines.
Fuel filter	The fuel filter removes contaminants and sediments from the diesel fuel. Periodic replacement of the fuel filter is necessary. <i>See the Periodic Maintenance Schedule on page 70</i> for the replacement frequency. Please note that the word “diesel” is implied throughout this manual when the word “fuel” is used.
Water separator	The water separator removes contaminants, sediment and water from diesel fuel going through the fuel filter. The separator is installed between the fuel tank and the fuel filter. Periodically replace the internal filter element and drain water.
Fuel tank	The fuel tank is a reservoir that holds diesel fuel. When fuel leaves the fuel tank, it goes to the water separator. Next, fuel is pumped to the fuel filter by the electric feed pump, then fuel is sent to the fuel supply pump. Fuel pressurized in the supply pump is sent to the rail and the excess fuel is returned back to the fuel tank. The fuel tank is a required engine component.
Fuel cooler Optional	This helps to keep the fuel cool. The cooler is equipped to the returning circuit to the fuel tank.
Side and top filler port (engine lubricating oil)	You can fill the crankcase with engine oil from either the side or top filler port depending upon which one is most convenient.
Starter motor	The starter motor is powered by the battery. When you turn the key switch in the operator’s console to the START position, the pinion gear of the starter engages with the ring gear installed on the flywheel and turns the flywheel.
Turbocharger (only applies to 3TNV86CT, 3TNV86CHT, 4TNV86CT, 4TNV86CHT, 4TNV98CT, 4TNV94CHT)	The turbocharger pressurizes the air coming into the engine. It is driven by a turbine that is energized by exhaust gases.
Intercooler (only applies to 3TNV86CHT, 4TNV86CHT, 4TNV94CHT)	To meet high output characteristics, an intercooler is installed to cool the air coming into the engine.

FUNCTION OF COOLING SYSTEM COMPONENTS

Components	Functions
Cooling system	<p>The TNV engine is liquid-cooled by means of a cooling system. The cooling system consists of a radiator, radiator cap, engine cooling fan, engine coolant pump, thermostat, and reserve tank.</p> <p>Note that all cooling system components are required for proper engine operation. Since some of the components are application specific, they must be carefully selected by an application engineer. The application specific items are not part of the basic engine package as shipped from the YANMAR factory.</p>
<ul style="list-style-type: none"> • Engine cooling fan 	<p>The engine cooling fan is driven by a V-belt which is powered by the crankshaft V-pulley. The purpose of the engine cooling fan is to circulate air through the radiator.</p>
<ul style="list-style-type: none"> • Engine coolant pump 	<p>The engine coolant pump circulates the engine coolant through the cylinder block and cylinder head and returns the engine coolant to the radiator.</p>
<ul style="list-style-type: none"> • Radiator 	<p>The radiator acts as a heat exchanger. As the engine coolant circulates through the cylinder block it absorbs heat. The heat in the engine coolant is dissipated in the radiator. As the engine cooling fan circulates air through the radiator, the heat is transferred to the air.</p>
<ul style="list-style-type: none"> • Radiator cap 	<p>The radiator cap controls the cooling system pressure. The cooling system is pressurized to raise the boiling point of the engine coolant. As the engine coolant temperature rises, the system pressure and the coolant volume increases. When the pressure reaches a preset value, the release valve in the radiator cap opens and the excess engine coolant flows into the reserve tank. As the engine coolant temperature is reduced, the system pressure and volume is reduced and the vacuum valve in the radiator cap opens allowing engine coolant to flow from the reserve tank back into the radiator.</p>
<ul style="list-style-type: none"> • Reserve tank 	<p>The reserve tank contains the overflow of engine coolant from the radiator. If you need to add engine coolant to the system, add it to the reserve tank, not the radiator.</p>
<ul style="list-style-type: none"> • Thermostat 	<p>A thermostat is placed in the cooling system to prevent engine coolant from circulating into the radiator until the engine coolant temperature reaches a preset temperature. When the engine is cold, no engine coolant flows through the radiator. Once the engine reaches its operating temperature the thermostat opens and allows engine coolant to flow through the radiator. By letting the engine warm up as quickly as possible, the thermostat reduces engine wear, deposits and emissions.</p>

ELECTRONIC CONTROL SYSTEM

WARNING

- The TNV series engines use a high pressure common rail system.
- The fuel is injected at extremely high pressure.
- Never disassemble the fuel system parts.
- Failure to comply may result in death or serious injury.
- If a malfunction occurs, contact your nearest YANMAR dealer or distributor.

WARNING

- Never use the ECU for purposes that are not intended by YANMAR; such as using unauthorized ECU, writing unauthorized data to ECU, leaving it broken, or removing sensors and actuators. Doing so could result in the violation of emission control regulations and will void the product warranty.
- Be sure to use the ECU in conjunction with the engines whose models or serial numbers are specified by YANMAR. Other ECU/engine combinations than specified will void the engine warranty.
- When replacing the fuel injector, you need to rewrite the fuel injection quantity adjustment data in the ECU. When replacing the ECU, you need to export data from the existing ECU to the new ECU. In order to operate as above, you need to connect the YANMAR genuine SA-D. Be sure to contact your authorized YANMAR dealer who can handle SMARTASSIST-DIRECT (SA-D). ECU that does not have the proper fuel injection quantity adjustment data written, or ECU that does not have the data transferred correctly will void the engine warranty.
- SA-D is also required to connect to your engine when replacing common rail parts. Contact your authorized YANMAR dealer or distributor.
- Improper use or misuse of the ECU may result in death or serious injury due to an abrupt and unexpected increase in engine speed.

NOTICE

Shut down the engine if the engine failure lamp comes on.
Continuing running the engine with the engine failure lamp being on may result in a serious malfunction of or damage to the engine, and will void the engine warranty.

NOTICE

Always check the battery for proper charge. Otherwise the electronically controlled engines may fail to start.

NOTICE

- Do not plug or unplug the ECU for a period of at least 60 seconds after power to the unit has been turned on or off.
- Do not touch connector pins of the ECU with bare hands. Doing so may result in corrosion of the connector pins and/or damage to the internal circuits of the ECU due to static electricity.
- Do not force a measuring probe into the female coupler. Doing so may cause contact failure of the connector pins, resulting in malfunction of the ECU.
- Take care to prevent water from entering the couplers when plugging or unplugging the connector. Water inside the couplers may cause corrosion, resulting in malfunction of the ECU.
- Avoid plugging/unplugging the connector more than approx. 10 times.
Frequent plugging/unplugging of the connector may cause contact failure of the connector pins, resulting in malfunction of the ECU.
- Do not use the ECU that has ever suffered drop impact.

NOTICE

High-pressure Cleaning

- High-pressure washing not recommended.
- Avoid using high-pressure washing for electronic or electric devices installed in, on or around the engine, including the ECU, relays and harness couplers.

Also, keep those devices away from water. Otherwise such devices may suffer malfunction due to water ingress into them.

The TNV engine is an electronic controlled engine that adopts three kinds of operating systems: 1. common rail system, 2. EGR system that controls the exhaust gas recirculation amount in accordance with the engine load and the number of rotation to comply with the EPA emission requirements (EPA2012), and 3. a system that controls the operation of the DPF regeneration mode by adjusting the intake throttle depending on the state (clogging) of the diesel particulate filter (DPF) of the post-processing device. **Figure 8** illustrates the outline of such electronic control system.

Features of the electronic engine control system include:

- Engine speed control schemes
Droop control/Isochronous control/Low-idling speed up/High-idling speed down/Auto deceleration
- Starting aid
Auto preheating
- Engine failure detection
- CAN communication with the control system of the driven machine
- Other

These functions are described in *Main Electronic Control Components and Features* on page 30. However components and features vary depending on the driven machine. For details, refer to the operation manual provided by the driven machine manufacturer for these functions.

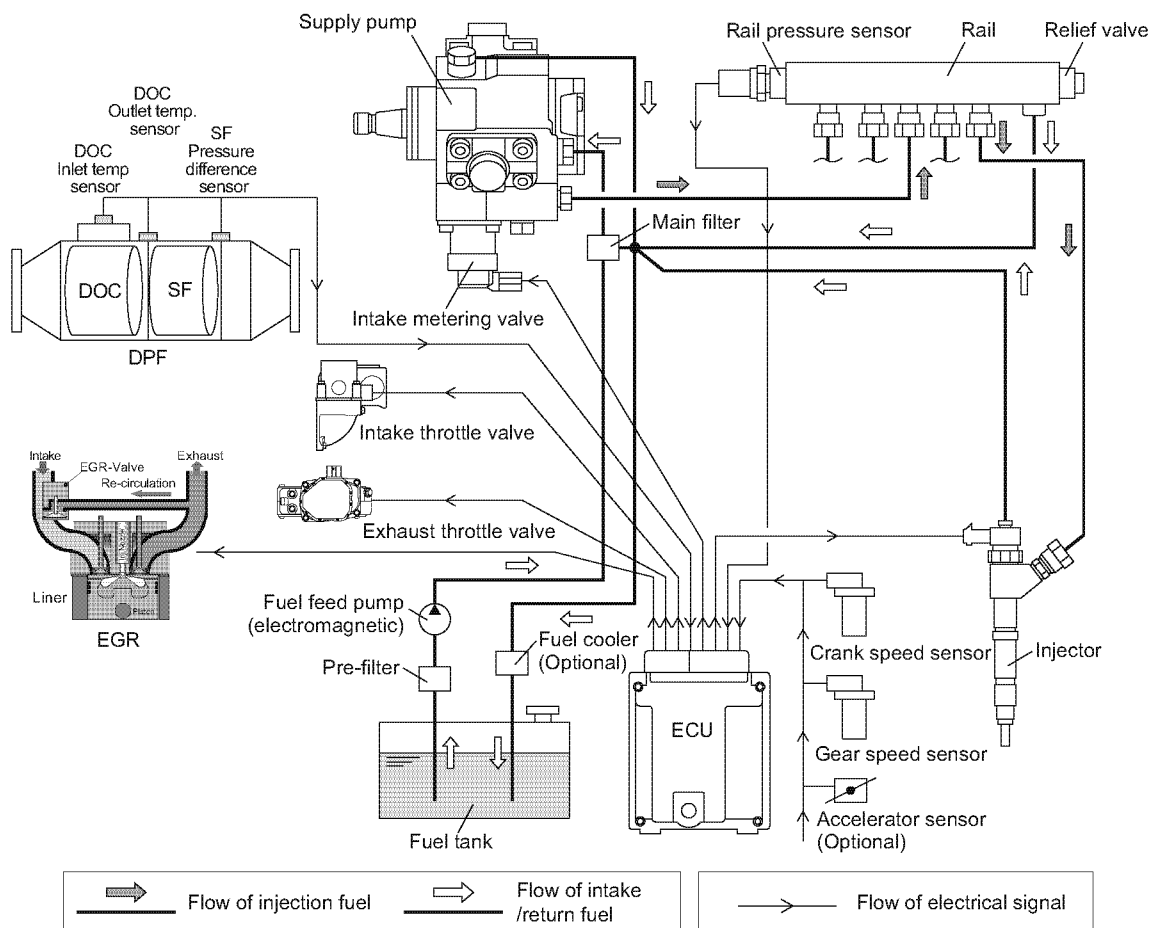

043932-03EN00

Figure 8

PRODUCT OVERVIEW

Main Electronic Control Components and Features

Component/feature	Description
Engine controller (ECU)	To be precise, E-ECU is an abbreviation for Engine Electronic Control Unit. By controlling the fuel injection timing, injection volume, injection pressure, and number of injection in accordance with the target speed indication entered from the accelerator sensor, the controller adjusts the engine speed and power. Depending on the above-mentioned speed and power, the controller controls the EGR opening. Also, the controller acts as the key station of the application function.
Fuel pump (supply pump)	The fuel pump supplies fuel to the common rail.
Common rail	The common rail stores the compressed high-pressure fuel from the supply pump and distributes fuel to the injector in each cylinder.
Fuel injector	The Fuel Injectors the high-pressure fuel from the rail to the engine combustion room after receiving a signal from the ECU in the most appropriate injection timing, injection volume, injection ratio, number of injection and spray condition.
EGR valve	Controls the exhaust gas recirculation flow rate depending on the engine speed/load signals from the ECU. It is installed on the top of the exhaust manifold.
Diesel Particulate Filter (DPF)	The Diesel Particulate Filter (DPF) consists of the diesel oxidation catalyst (DOC) and the soot filter (SF). It is a device to prevent the discharge of particulate matter (PM) by oxidizing the hazardous constituent with the DOC and collecting the PM in the exhaust gas with the SF.
Intake throttle valve	The intake throttle adjusts the amount of intake air in the engine and controls the exhaust temperature to assist the DPF regeneration.
Exhaust throttle valve	The exhaust throttle adjusts the back pressure of the exhaust gas by the valve attached to the discharge port area of the exhaust manifold. This controls the exhaust temperature and assists the DPF regeneration.
Optional	
Accelerator sensor (machine setting)	Unlike mechanical governors, the electronically controlled common rail system has no governor lever. In stead, the accelerator sensor is required to set the engine target speed. The ECU determines the target speed by catching the size of voltage from the accelerator sensor. The accelerator sensor is located in the machine operator part. Specification only for constant speed engines such as those for electric generator do not require accelerator sensors because the engine speed can be shifted via a panel switch.
Optional	CAN communication capability is available as an option.
Engine failure lamp	The failure lamp is installed on the operator's console and ECU displays the occurrence of failures to inform the operator of the initial diagnosis of failures when an error is detected in the ECU or the electronic control system. The display pattern varies depending on the machine.
Optional	

Component/feature		Description
SMARTASSIST-DIRECT (SA-D)		Allows the operator to troubleshoot the cause of a problem based on detailed information regarding the defects occurring in the ECU internal control information. The SMARTASSIST-DIRECT can also be used for data maintenance tasks including ECU internal programming, mapping and adjustment values. For more details, see <i>Troubleshooting of Electronic Control System on page 93.</i>
Option for service		
Engine coolant temperature sensor		Allows the fuel injection volume and ERG to be controlled in engine cold-start conditions.
On-glow control (preheat)		At cold start, when the key switch is set to the ON position, the system automatically energizes the glow plug relay and keeps it energized for particular amount of time depending on the engine coolant temperature. (Maximum 15 seconds) The preheat indicator lights up while the relay is being energized. When the indicator goes out, turn the key switch to the "START" position to start the engine.
Droop control	Standard with VM series	Reduces the engine speed by a certain percentage from no load to full (rated) load in steady state operation. The same percentage droop is maintained even when the load increases at any no-load speed.
Isochronous control	Standard with CL series Optional with VM series	Offers a constant engine speed from no load to full load. The engine speed does not decrease even when the load increases at any no-load speed.
Low-idling speed up		When the temperature of the engine cooling water is as low 10 °C or below, raise the low idle speed to 1000 min ⁻¹ or more to boost the engine warm-up. When the cooling water temperature reaches the set value, it will return to the original low idle speed. This feature is not required for engines with low idle speed of 1000 min ⁻¹ or higher.
T/C protection control at low temperature		When starting at low temperature, if the temperature of the cooling water at the time when the engine start is complete is -15 °C (5 °F) or lower, limit the high idle speed to 1500 min ⁻¹ for ten seconds from the point when the engine start is complete, in order to prevent seizure of the turbocharger. The control of accelerator operation to lower the high idle speed to below 1500 min ⁻¹ after the ten seconds will be canceled.
High idle speed down at low temperature	Optional	When starting at low temperature (-30 °C, -22 °F), lower the high idle speed by about 150 min ⁻¹ , and shorten the disappearing time of blue-white smoke. When the cooling water temperature reaches 30 °C (86 °F) or over, the control for accelerator operation to lower the speed to below the high idle speed limit at low temperature will be cancelled.
Auto deceleration	Optional	Brings the running engine in low idle mode automatically when the accelerator pedal is not operated for a predetermined period of time. When the pedal is operated, i.e., the accelerator sensor is activated, the low idle mode is cancelled.

Electronic Engine Speed Control

■ Speed control

The electronically controlled engines have no governor lever. For these engines, the position signal of the throttle lever or accelerator pedal of the driven machine is converted into an electric signal by the accelerator sensor **Figure 9**, which is then delivered to the fuel injector through the ECU **Figure 10**, allowing the engine speed to be controlled.

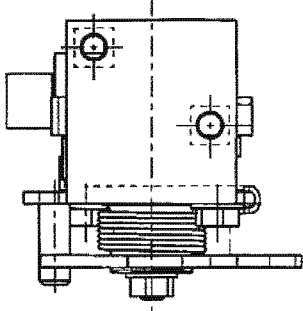
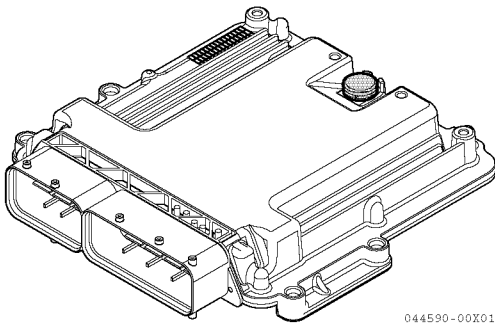

Figure 9

Bosch common rail ECU



Denso common rail ECU

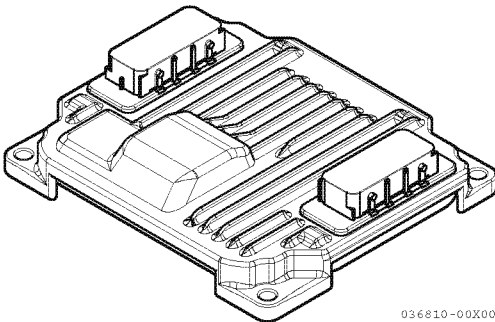

Figure 10

■ Engine speed curves

Figure 11 shows typical engine speed curves that outline the relationship between engine speed and load.

Droop control

The VM series engines for general use are designed so that the engine speed is reduced by a certain percentage from 30 % load to full rated load. See curves (1) in **Figure 11** below. The same percentage droop is maintained at any no-load speed.

Isochronous control

The CL series consists of isochronous design engines, the speed of which is kept constant from no load to full rated load. See curves (2) in **Figure 11** below.

Some VM series engines for general use may be custom-engineered and have the isochronous capability. Consult the operation manual for the driven machine for application details of such engines.

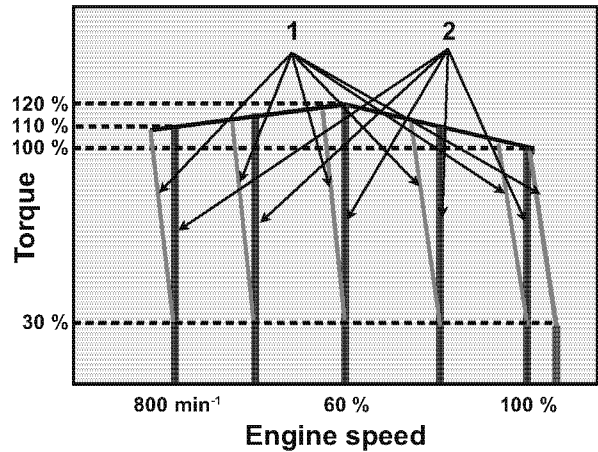

Figure 11

■ Other engine speed control

Low-idling speed up

When the engine coolant temperature is as low as 10 °C or below, increase the low idle speed to 1000 min⁻¹ or higher to encourage engine warm-up. When the coolant temperature reaches a predetermined value, the engine speed comes back to low idle speed. This may not idle up in some of the engines.

Turbocharger protection control at low temperature

For turbocharger-equipped types, when starting at low temperature, if the engine coolant temperature is -15 °C or below at the point of completing the engine start, limit the high idle speed to 1500 min⁻¹ to prevent seizure of the turbocharger. After 10 seconds from the engine start, by operating the accelerator to 1500 min⁻¹ or below, this control will be off. When you do not operate the accelerator, it will continue at 1500 min⁻¹.

Basically, this function is included in standard specification. However, it may not be equipped to some of the engines. For details, consult the operation manual for the driven machine.

Low temperature high idle-down function (optional)

When starting at low temperature (-30 °C or below), reduce the high-idling speed by about 150 min⁻¹ to shorten the time for blue-white smoke to disappear. When the engine coolant temperature is 30 °C or higher, by operating the accelerator to a speed lower than the low-temperature high-idling speed limit, this control will be off.

This can be set optionally for engines with rated speed of 2300 min⁻¹ or higher.

Auto deceleration (optional)

This feature brings the running engine in low idle mode automatically when the accelerator pedal is not operated for a predetermined period of time. When the pedal is operated, i.e., the accelerator sensor is activated, the low idle mode is cancelled.

This control is available with the combination of external switches, etc. However, it is an optional function. For details, consult the operation manual for the driven machine. 4TNV94CHT does not include this function.

Others

Depending on the selection of the external switch and CAN communication, other functions may also be equipped. For details, see the operation manual for the driven machine.

PRODUCT OVERVIEW

Diesel Particulate Filter (DPF)

The DPF consists of the Diesel Oxidation Catalyst (DOC) and the Soot Filter (SF), held by a case that sends the exhaust gas to the DOC and the SF. The role of the DPF is to prevent the discharge of PM by oxidizing the hazardous constituents with the DOC and collecting the PM with the SF. The PM clogs the SF if left there and the engine performance decreases, so a means of regeneration is required.

YANMAR engines use a continuous regeneration method. While continuing the operation, the DPF collects the PM and is regenerated at the same time. To perform the regeneration, the PM collected in the SF is combusted with NO₂ generated in the DOC and O₂ in the exhaust gas. At the same time, the DOC purifies the exhaust gas elements such as HC and CO into H₂O and CO₂.

Outline of Diesel Particulate Filter (DPF)

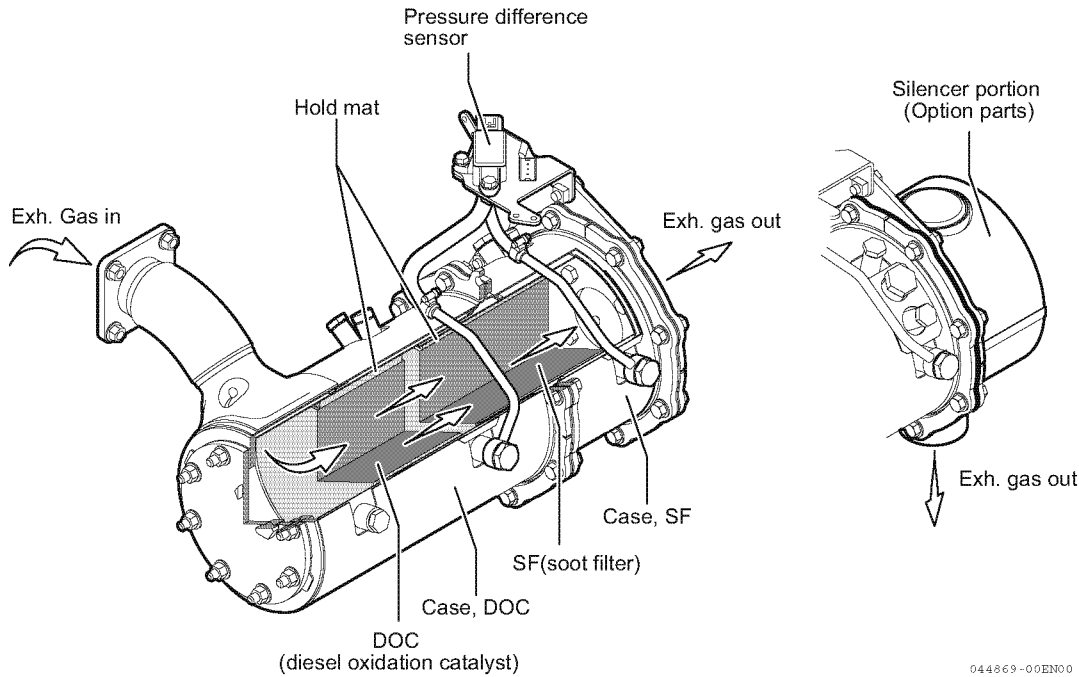

Figure 12

Apart from the PM, ash also collects in the SF. This comes mostly from metallic components in the additives to the lubricating oil. Part of the lubricating oil is burnt in the high temperature combustion chamber and exhausted along with the combustion gas. In that case, metallic components are collected together with the PM in the SF. However, because the amount of ash is very little compared to the PM, it does not clog the SF immediately. Because ash is a metallic component, it cannot be combusted in the DPF for treatment like the PM. Therefore, ash is over-accumulated in the SF over a long period of time. This increases the pressure loss and has adverse effects on the engine. In this case, maintenance must be performed to remove the SF with the accumulated ash from the DPF. Yanmar recommends to do this maintenance once every 6,000 operating hours.

Be sure to use the specified fuel and lubricating oil so that the DPF can fulfill its function. For fuel, use diesel fuel (ultra-low sulfur) with a sulfur mass of 15 ppm or lower. If you use a fuel other than the specified, performance of the catalyst contained in the DOC deteriorates rapidly due to sulfur. Because of this, the DPF cannot develop its regeneration capabilities and PM accumulates easier. This leads to increased fuel consumption and a deterioration of general engine receptiveness caused by decreased engine performance and frequent switching to the regeneration mode.

For lubricating oil, use low ash oil. If you use any other than the specified lubricating oil, a large amount of ash is vented through the exhaust and the DPF will clog within a short period of time. This will not only cause the engine output to decrease and the fuel costs to increase, but also makes earlier maintenance of the SF necessary.

■ **Overview of Diesel Particulate Filter (DPF) regeneration control**

Electrical components such as the DPF differential pressure sensor, temperature sensor, and intake throttle are installed in the DPF. If the DPF cannot perform continuous regeneration due to low load operation, the ECU uses these electrical components to control assisted DPF regeneration (DPF regeneration control) automatically to prevent PM from over-accumulating.

■ **Self-regeneration**

Regeneration without the use of regeneration assistance devices (normal)

During the operation at high speed or high load, the exhaust temperature rises and PM is continuously combusted and eliminated.

■ **Assisted regeneration**

Regeneration with the use of assistance devices (e.g. the intake throttle)

When the differential pressure in the SF inlet/outlet in the DPF rises, the differential pressure sensor installed to the DPF detects the increase. The ECU commands the intake throttle to open the throttle according to the detected differential pressure to adjust the amount of engine intake air. The ECU also controls the regeneration by performing after-injection*1 to increase the exhaust temperature. At this time, the EGR valve is closed.

■ **Reset regeneration**

Regeneration with the combined use of assisted regeneration and post-injection

50 hours after the initial operation, and every 100 hours of operation thereafter, the assisted regeneration and post-injection*1 are automatically used together to control regeneration by increasing the exhaust temperature to burn off and remove PM.

These automatic regenerations can be performed during operation. No special operation is required for the operator. The following conditions may occur due to the characteristics of the DPF system, but they are not malfunctions.

- The engine sound may change due to the adjustment of intake throttle valve and degree of opening of the EGR valve when starting and completing the DPF regeneration.
- White smoke may be discharged from the exhaust pipe right after starting a cold engine or during acceleration.

This is due to discharge of water vapor. When the exhaust temperature increases, the white smoke disappears. Always perform the DPF regeneration in a well-ventilated and safe location.

- The exhaust gas is purified through the catalyst installed in the DPF, so the smell of the exhaust gas is different from the exhaust gas of a conventional diesel engine.

*1: After-injection and post-injection

Both of these are functions to inject fuel with a delay following the main injection. However, the post-injection is slightly more delayed than the after-injection.

That allows the exhaust temperature to increase to assist DPF regeneration.

CAUTION

- **During reset regeneration, post-injection is used and fuel is burned directly inside the DPF (burned by chemical reaction inside the DOC). Through this heat, regeneration occurs inside the SF, but the combustion increases the temperature of the exhaust gas to close to 600 °C (1112 °F). Stay away from the exhaust gas. Extremely hot exhaust gas may burn you. Be careful that neither people nor flammable materials are near the exhaust gas outlet.**
- **Post-injection can cause the fuel consumption to increase by a small amount.**
- **Through this genuine YANMAR regeneration method, the dilution of the lubricating oil with fuel caused by the post-injection is kept to a minimum, but some dilution is possible for low-load operation (low temperature exhaust gas) of fork lifters or similar machines. Make sure that you do a daily check of the oil level.**

■ Stationary regeneration

Although the DPF performs the regeneration control, if the operation conditions with idling at no load and low speed/low load operation are frequently repeated, the PM may not be regenerated. If the ECU determines that performing the stationary regeneration is required at this time, the DPF regeneration request lamp lights up.

If the DPF regeneration request lamp is lit, immediately conduct the stationary regeneration by performing the following operation.

If the operation is continued with the DPF regeneration request lamp lit up, an excessive amount of PM will accumulate. Abnormal combustion of PM may cause fire and damage to the DPF.

CAUTION

Observe the following conditions when performing stationary regeneration.

- Never operate the engine in an enclosed area. Accumulation of gas may cause carbon monoxide poisoning.
- Regeneration causes the exhaust gas temperature to increase. To prevent fire, make sure that there are no flammable materials around the exhaust gas outlet.
- Never touch the exhaust pipe. The temperature of the exhaust gas can be extremely high. Never stand near or around the exhaust gas outlet.

■ Operation procedures of stationary regeneration

1. Move to a well-ventilated and safe location.
2. Move the accelerator lever to the lowest position and operate the engine in idling.

Note: If the DPF regeneration inhibit switch is installed, turn the DPF regeneration inhibit switch to "Regeneration Permitted".

3. Operate the interlock mechanism including the parking brake and neutral lever to unlock the interlock function (stop the driven machine).

Note: When the ECU verifies that the interlock mechanism is unlocked with the regeneration interlock switch, the DPF regeneration approval lamp starts flashing.

4. Press the DPF regeneration request switch for 3 seconds (standard) or longer to start the stationary regeneration. (The time required to start the stationary regeneration can be changed. Refer to the operation manual for the detailed operation.)
 - When the stationary regeneration starts, the engine speed increases gradually to high idle speed. Then the reset regeneration is performed at that operation condition.
 - When the stationary regeneration starts, the DPF regeneration request lamp turns off, the DPF regeneration approval lamp switches from blinking to continuously lit, and the exhaust temperature warning lamp lights up.
 - The stationary regeneration is complete after approximately 25 to 30 minutes.
 - If you want to interrupt the stationary regeneration, perform one of the following operations.
 - Turn the interlock switch to "Regeneration Disabled".
 - Turn the DPF regeneration inhibit switch to "Regeneration Prohibited".
 - Raise the accelerator lever above the lowest position.
 - Turn off the power switch.
5. When the above-mentioned time has elapsed, the engine speed decreases to low idling, the regeneration approval lamp and the exhaust temperature warning lamp turn off, and the stationary regeneration is complete.

■ Precautions for stationary regeneration

- Do not disconnect SMARTASSIST-DIRECT (SA-D) or the computer while performing the stationary regeneration. Check the remaining battery level to avoid the computer from shutting down. Prepare the sufficient battery that can perform the stationary regeneration for at 30 minutes to 1 hour.
- Be sure to check the remaining fuel level to avoid the engine from running out of fuel while performing the stationary regeneration. Stationary regeneration normally takes 25 to 30 minutes to complete. Prepare sufficient fuel that can run the engine for at least 1 hour.
- Make sure that no other failure other than excessive deposits is observed.

■ **Recovery regeneration (optional)**

The DPF can not be regenerated by the reset regeneration or the stationary regeneration when the excessive PM is accumulated. Therefore, optional recovery regeneration function is available. The recovery regeneration requires longer regeneration time and lower temperature than that of the reset regeneration and the stationary regeneration. However, the function varies depending on the driven machine. For details, refer to the operation manual provided by the driven machine manufacturer for these functions.

■ **Precautions for recovery regeneration**

- Do not disconnect SMARTASSIST DIRECT (SA-D) or the computer while performing the recovery regeneration. (Check the remaining battery level. Recovery regeneration takes approximately 4 hour to complete.)
- Be sure to check the remaining fuel level to avoid the engine from running out of fuel. (Recovery regeneration requires sufficient fuel that can run the engine for at least 4 hour.)
- Make sure that no other failure other than excessive deposits is observed.

NOTICE

If DPF is clogged quickly, check the following items.

- Please use the specified fuel. Fuel with a high sulfur content can deteriorate the catalyst performance inside the DOC, resulting in deterioration of DPF regeneration performance and PM accumulation.
- Please use the specified lubricating oil. If lubricating oil contains a large amount of ash, the ash content is vented through the exhaust, causing the DPF to clog quickly.
- Soot accumulates easily due to incomplete combustion as the resistances in the intake/exhaust system increase. Periodically check and clean the air cleaner, EGR valve, and exhaust throttle (if equipped).
- For more information on factors causing black smoke, see *Troubleshooting Chart on page 90*.

PRODUCT OVERVIEW

■ Diesel Particulate Filter (DPF) service

DOC: Maintenance-free parts
Replace every 9000 operation hours.

SF: Parts that require maintenance
If your engine is equipped with DPF cleaning alarm, clean the DPF when the alarm lamp comes on. If your engine is not equipped with DPF cleaning alarm, clean the DPF on 6000 hours of operation.
For cleaning the DPF soot filter, contact your authorized YANMAR dealer or distributor.

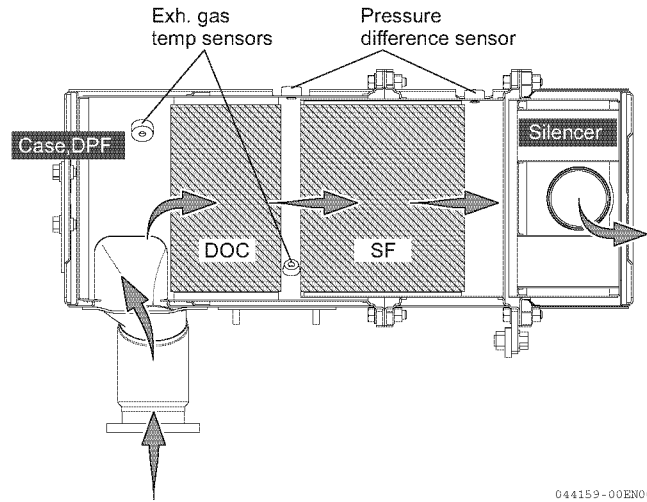

044159-00EN00

Figure 13

Item	Engine type	Emission warranty (Useful life)	Periodic maintenance interval	
			Limit to use	Clean
DOC	19 - 37 kW	5000 hours or 7 years, whichever comes first	9000 hours of operation	N/A
	≥ 37 kW	8000 hours or 10 years, whichever comes first		
SF	19 - 37 kW	5000 hours or 7 years, whichever comes first	9000 hours of operation	With DPF cleaning alarm: when the alarm comes on Without DPF cleaning alarm: on 6000 hours of operation
	≥ 37 kW	8000 hours or 10 years, whichever comes first		

Intake Throttle

The intake throttle is a device that controls the amount of the engine air intake. The TNV series engines use it for the combustion of soot collected inside the DPF. The intake throttle is driven by the DC motor. The ECU controls the appropriate degree of opening of the throttle depending on the engine speed and load conditions. Accordingly, the engine takes in the minimum required amount of air to increase the exhaust temperature and burn soot inside the DPF.

■ Precautions for handling the intake throttle

- Do not use a throttle after you have dropped it. Even if it appears okay on the outside, it may have internal damage.
- Do not apply excessive impact or load to the throttle.
- Do not touch the stop screw part, as it has already been adjusted.
- Prevent any foreign matter including oil, dust, and water droplets from entering the air passage part.
- Do not remove the sensor cover installation rivet.
- Consider static electricity and prevent static electric charge of the human body when handling the throttle.
- Do not touch the sensor cover terminal directly.
- Do not touch the throttle valve with your hands when the throttle is energized. Your hands may get pinched in the valve and get injured.
- Do not check operation with the installation surface of the throttle unit pointing down, as the valve protrudes from the installation surface.
- Prevent water and foreign matter from entering the connector connection part.

Exhaust Throttle

The exhaust throttle adjusts the back pressure of the exhaust gas by the valve attached to the discharge port passage area of the exhaust manifold. This controls the exhaust temperature and assists the DPF regeneration. Exhaust throttle valve is driven by DC motors and it controls the valve according to the appropriate opening indicated by the ECU based on engine speed or fuel injection volume. Exhaust throttle valve is in a fully opened state during normal operation. (Figure 14)

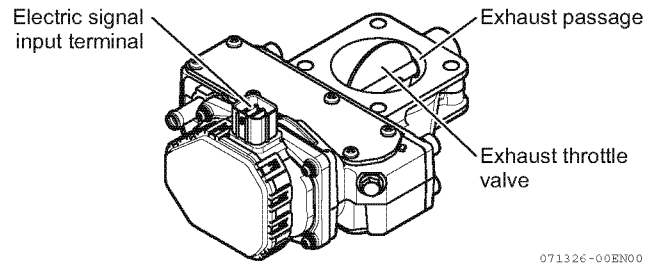

Figure 14

Installation Position of Sensors for Electronic Control System

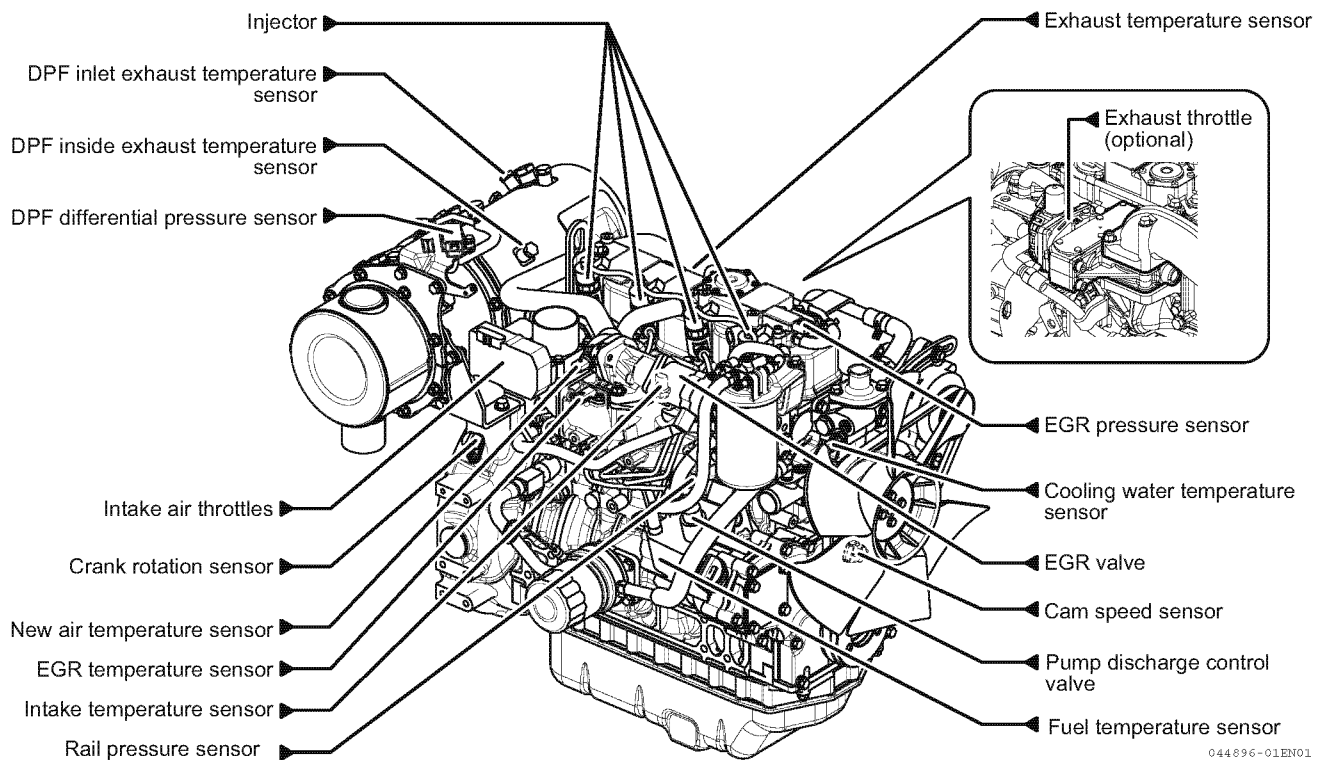

Figure 15

GAUGES AND INDICATORS

The operator's console provides you with the means to start and stop the unit and a series of gauges and indicators that inform you about the current status of the engine. This is a required engine component. Since the operator's console is application specific, it must be carefully selected by an application engineer. It is not part of the basic engine package as shipped from the YANMAR factory.

NOTICE

The illustrations and descriptions of optional equipment in this manual, such as the operator's console, are for a typical engine installation. Refer to the documentation supplied by the optional equipment manufacturer for specific operation and maintenance instructions.

Gauges

The gauges located on the operator's console may vary depending on the indication system and optional equipment of the machine. Refer to the operation manual provided by the driven machine manufacturer for details.

1 Tachometer

The tachometer display shows the engine speed in revolutions per minute (RPM).

2 Engine coolant temperature

The engine coolant temperature display shows the temperature of the engine coolant.

3 Engine lubricating oil pressure

The engine lubricating oil pressure display shows the pressure of the engine lubricating oil.

4 Hourmeter

The hourmeter display shows the total number of hours the engine has run. This is useful for planning the *Periodic Maintenance Procedures* on page 72.

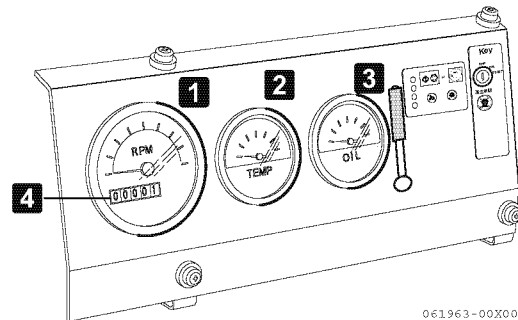

Figure 16

Indicators and Switches

The following indicators are located on a typical operator's console.

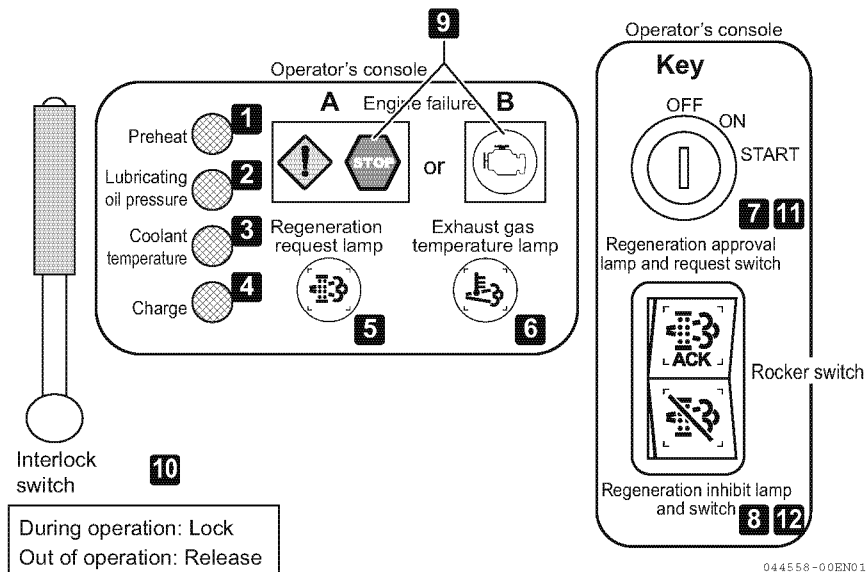

Figure 17

1 Preheat indicator

Note that on this type of panel you must turn the key to the ON position to activate the glow plugs for preheating during engine cold starting. The preheat function is automatically activated based on the coolant temperature (On-glow control). Preheat indicator will come on at this point. When the preheat indicator goes out, you can turn the key switch to START.

2 Lubricating oil pressure indicator

This indicator will come on when you turn the key to the ON position. When the engine starts, the indicator goes out as the engine lubricating oil pressure rises. This indicator will come on if the engine lubricating oil pressure is below or exceeds normal limits. For details, See *Troubleshooting Chart on page 90*.

3 Coolant temperature indicator

This indicator will come on if the coolant temperature exceeds normal limits. For details, See *Troubleshooting Chart on page 90*.

4 Battery charge indicator

This indicator will come on when you turn the key to the ON position. When the engine starts, the alternator (dynamo) generates power and the indicator goes out as the battery charging starts. This indicator will come on if there is a problem in the charging system. This indicator does not come on if the battery is discharged. For details, See *Troubleshooting Chart on page 90*.

In addition to the above indicators, the engine described in this manual is equipped with a diesel particulate filter (DPF) system for post-treatment of the exhaust gas. Warning lamps and switches to control combustion of the PM (DPF regeneration) accumulated in the soot filter (SF) inside the DPF are also equipped. Refer to *Overview of Diesel Particulate Filter (DPF) regeneration control on page 35* for DPF regeneration control. These lamps may also vary depending on the machine. Refer to the operation manual provided by the driven machine manufacturer for details.

PRODUCT OVERVIEW

5 DPF regeneration request lamp

Comes on when the ECU determines that stationary regeneration is required. Push the DPF regeneration request switch to start stationary regeneration. Refer to *Stationary regeneration on page 36* for the detailed procedure of stationary regeneration. The lamp goes out when stationary regeneration is started.

If the DPF regeneration inhibit switch is provided as an option, the lamp also comes on after 100 hours from the last reset regeneration or stationary regeneration with the regeneration inhibit switch set to "ON".

6 Exhaust gas temperature lamp

Comes on during reset regeneration and stationary regeneration. Goes out when those regenerations are complete.

7 DPF regeneration approval lamp

Flashes during stand-by before stationary regeneration and comes on when stationary regeneration has started. The lamp goes out when stationary regeneration is complete.

8 DPF regeneration inhibit lamp (optional)

Comes on when the DPF regeneration inhibit switch (12) is turned to "Regeneration Inhibited".

9 Engine failure lamp

There are two types of engine failure lamps in the standard specification model as shown in **Figure 17**; only the failure lamp or the combination of an amber warning lamp and engine stop lamp is equipped.

1. Amber warning lamp



- Comes on when engine faults are detected. Contact your authorized YANMAR industrial engine dealer or distributor.
- Flashes when stationary regeneration is required.
- Flashes when ash cleaning (Level 1) is required. Contact your authorized YANMAR industrial engine dealer or distributor.

2. Engine stop lamp



- Comes on when severe engine failures are detected. Stop the engine immediately and contact your authorized YANMAR industrial engine dealer or distributor.
- Flashes when ash cleaning (Level 2) is required. Contact your authorized YANMAR industrial engine dealer or distributor.

3. Fault indicator lamp

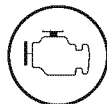

- Comes on when engine faults are detected.
- Comes on when stationary regeneration or ash cleaning is required. The regeneration lamp also comes on when stationary regeneration is required. In this case, perform stationary regeneration. Other than the stationary regeneration request, contact your authorized YANMAR industrial engine dealer or distributor.

The lamps may vary depending on the machine. Refer to the operation manual provided by the driven machine manufacturer for details.

10 Interlock switch

The engine speed automatically changes according to the signals from the ECU during stationary regeneration. Therefore, operate the interlock mechanism including the parking brake and neutral lever to unlock the interlock function. Use an interlock switch that allows the ECU to verify that the driven machine is stopped.

When the ECU verifies that the interlock mechanism is unlocked with the regeneration interlock switch, the DPF regeneration approval lamp starts flashing.

11 DPF regeneration request switch

This switch is used to start the stationary regeneration manually.

12 DPF regeneration inhibit switch

This switch is used to inhibit the reset regeneration manually.

CONTROLS

Key Switch

The key switch for the operator's console illustrated in **Figure 15** has positions - OFF, ON, START.

1 OFF

This is the position to shut down the engine. Electric current to the gauges and indicator is also shut off. You can insert and remove the key in this position.

2 ON

This is the position of the key while the engine is running. When you turn the key to the ON position while the engine is not running, the gauges, indicators, electric fuel pump, and auxiliary devices are energized.

When the key switch is set to the ON position, the system automatically energizes the glow plug relay and keeps it energized for a particular amount of time, depending on the coolant temperature. The preheat indicator also comes on at the same time during energization. You can turn the key to START when the preheat indicator goes out.

3 START

This is the position to start the engine. As soon as the engine starts, release your hand from the key and it will automatically return to the ON position. Some key switches may be equipped with a feature that prevents you from turning the key from ON to START while the engine is running. When you operate a key switch with this feature, you cannot turn the key to the START position without first returning the key to the OFF position.

NOTICE

Never hold the key in the START position for longer than 15 seconds or the starter motor will overheat.

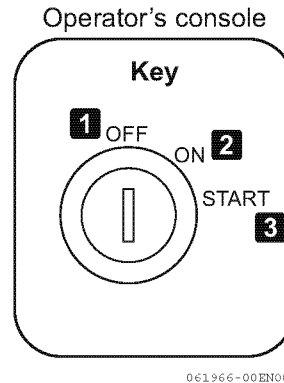

Figure 15

Glow Plugs

A glow plug is installed on each cylinder head, protruding into the piston chamber.

The glow plug assists the engine start in cold conditions. When the key switch is set to the ON position, the system automatically energizes the glow plug relay and keeps it energized for a particular amount of time, depending on the coolant temperature. The preheat indicator comes on while energizing. Start the engine after the indicator goes out.

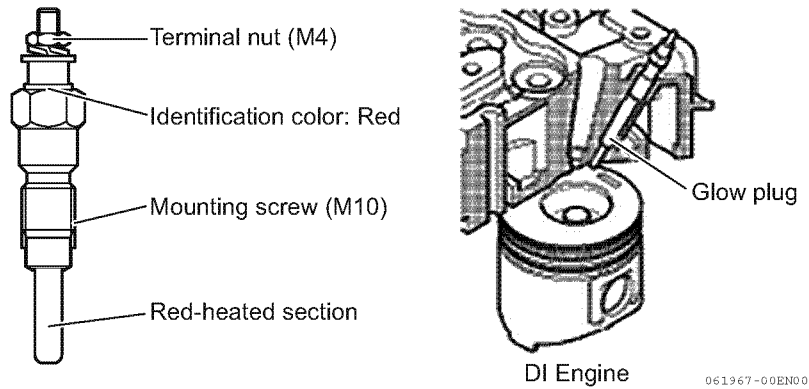

Figure 16

This Page Intentionally Left Blank

BEFORE YOU OPERATE

This section of the Operation Manual describes the diesel fuel, engine lubricating oil, and engine coolant specifications and how to replenish them. It also describes the daily engine checkout.

DIESEL FUEL

Diesel Fuel Specifications

Diesel fuel should comply with the following specifications. The table lists several worldwide specifications for diesel fuels.

Diesel fuel specification	Location
ASTM D975 No. 1D S15 No. 2D S15	USA
EN590:96	European Union
ISO 8217 DMX	International
BS 2869-A1 or A2	United Kingdom
JIS K2204 Grade No. 2	Japan
KSM-2610	Korea
GB252	China

■ Additional technical fuel requirements

- When operating the engine in cold districts or high altitudes, the fuel cetane number should be equal to 45 or higher.
- **The sulfur content must not exceed 15 ppm by volume. A higher sulfur content fuel may cause sulfuric acid corrosion in the cylinders of the engines. Especially in U.S.A. and Canada, Ultra Low Sulfur fuel must be used.**
- Use the fuel that can be used where the temperature is 12 °C (53.6 °F) lower than the expected lowest temperature to prevent the fuel from freezing.
- Bio-diesel fuels. *See Biodiesel fuels on page 49.*
- Water and sediment in the fuel should not exceed 0.05 % by volume.
- Ash content not to exceed 0.01 % by volume.
- Carbon residue content not to exceed 0.35 % by volume. Less than 0.1 % is preferred.
- Total aromatics content should not exceed 35 % by volume. Less than 30 % is preferred.
- PAH (Polycyclic Aromatic Hydrocarbons) content should be below 10 % by volume.

- Metal content of Mg, Si, and Al should be equal to or lower than 1 mass ppm. (Test analysis method JPI-5S-44-95)
- The diesel fuel should be free from Zn and Na.
- Lubricity: Wear mark of WS1.4 should be Max. 0.018 in. (460 µm) at HFRR test.

■ Precautions and concerns regarding the use of diesel fuel

- Never use kerosene.
- Never mix kerosene or used engine oil with the diesel fuel.
- Never use residual fuels that cause diesel fuel filter clogging and carbon deposits on the nozzles.
- Never use fuels stored for long time in a drum can or the like.
- Never keep fuel in containers with zinc plating on the inside.
- Never use fuels purchased from unauthorized dealer.
- Fuel additives are not recommended. Some fuel additives may cause poor engine performance. Consult your YANMAR representative for more information.

■ Biodiesel fuels**1. General Description of Biodiesel**

(a) Biodiesel is a renewable, oxygenated fuel made from agricultural and renewable resources such as soybeans or rapeseeds. Biodiesel is a fuel comprised of methyl or ethyl ester-based oxygenates of long chain fatty acids derived from the transesterification of vegetable oils, animal fats, and cooking oils. It contains no petroleum-based diesel fuel but can be blended at any level with petroleum-based diesel fuel. In case it is not blended with petroleum-based diesel fuel such biodiesel is referred to as “B100”, which means that it consists of 100 % (pure) biodiesel. However, most common biodiesel is blended with conventional (petroleum-based) diesel fuel. The percentage of the blend can be identified by its name. For example, B7 consisting of 7 % biodiesel and 93 % conventional petroleum-based diesel fuel and B20 consisting 20 % biodiesel and 80 % conventional diesel fuel. Raw pressed vegetable oils are not considered to be biodiesel.

(b) Advantages of Biodiesel:

- Biodiesel produces less visible smoke and a lower amount of particulate matter.
- Biodiesel is biodegradable and nontoxic.
- Biodiesel is safer than conventional diesel fuel because of its higher flash point.

Following the increased interest in the reduction of emissions and the reduction of the use of petroleum distillate based fuels; many governments and regulating bodies encourage the use of biodiesel.

(c) Disadvantages of Biodiesel:

Concentrations that are higher than 7 % of biodiesel (higher than B7) can have an adverse affect on the engine’s performance, its integrity and/or durability. The risk of problems occurring in the engine increases as the level of biodiesel blend increases. The following negative affects are exemplary and typical for the usage of high concentrated biodiesel blends:

- Biodiesel can accelerate the oxidation of Aluminum, Brass, Bronze, Copper and Zinc.

- Biodiesel damages, and finally seeps through certain seals, gaskets, hoses, glues and plastics.
- Certain natural rubbers, nitride and butyl rubbers will become harder and more brittle as degradation proceeds when used with biodiesel.
- The deteriorated biodiesel creates deposits in the engines.
- Due to its natural characteristic, biodiesel will decrease the engine output by approximately 2 percent (in case of B20) comparing to conventional (petroleum-based) diesel fuel.
- The fuel consumption ratio will increase by approximately 3 percent (in case of B 20) comparing to conventional diesel fuel.

2. Approved Engines

All of the following engine series of YANMAR can be operated with biodiesel with concentrations up to B20. In case of using biodiesel fuel up to B7 concentrations, no special preparations etc. have to be made and the original operating conditions and service intervals as stated in the operating manuals apply. In case of running below indicated engines with biodiesel concentrations above B7 up to B20, the required operating conditions (see below No. 4) have to be observed.

The following listed engines can be run with B20 biodiesel:

- 3TNM68, 3TNM72, 2TNV70, 3TNV70 and 3TNV76
- 3TNV82A, 3TNV84, 3TNV84T, 3TNV88, 4TNV84, 4TNV84T, 4TNV88, 4TNV94L 4TNV98 and 4TNV98T
- 4TNV106 and 4TNV106T
- 4TNE92, 4TNE94L and 4TNE98 for forklift application
- 3TNM74F, 3TNV74F and 3TNV80F
- 3TNV88F
- 3TNV88C, 3TNV86CT, 3TNV86CHT, 4TNV88C, 4TNV86CT, 4TNV86CHT, 4TNV98C and 4TNV98CT High Pressure Common Rail
- 4TNV94CHT High Pressure Common Rail

BEFORE YOU OPERATE

3. Approved Fuel

In case of using biodiesel (only concentrations up to B20) such fuel should comply with the below recommended standards. However, raw pressed vegetable oils are not considered to be biodiesel and are not acceptable for use as fuel in any concentration in YANMAR engines.

(a) EN14214 (European standard) and/or ASTM D-6751 (American standard).
In North America, biodiesel and biodiesel blends must be purchased from the BQ-9000 accredited producers and BQ-9000 certified distributors.

(b) All applicable engines can be operated with biodiesel fuels with concentration levels up to B20 (20 % bio-fuel blend). (However in Japan, the legally allowed maximum concentration for on-road applications is B5.)

If the concentration is B7 (7 %) or lower, the fuel can be used for all of the YANMAR's industrial engines, and does not require any special preparations or operating conditions. However, please strictly follow the standard operating conditions included in the manual.

4. Conditions for the Operation with Biodiesel (above B7 through B20)

When operating your applicable YANMAR engine (No. 2) with biodiesel blends concentrated above B7, we seriously recommend observing the following operation, service and maintenance conditions:

(a) The original service interval of the below stated services as indicated in the respective YANMAR engine standard operation manual should be halved (please refer to your own manuals for the each service interval):

- Replacement interval of the engine lubricating oil filter, engine lubricating oil and the fuel filter.
- Cleaning interval of the water separator.
- Draining interval of the fuel tank.

(b) Have the fuel injector inspected and cleaned every 1000 hours.

It is strongly recommended to replace the fuel hoses after 2000 operating hours or 2 years whichever comes first same as conventional diesel fuel used.

(c) Replacement of the following parts before using the recommended biodiesel:
(only for the operation with biodiesel above B10 through B20)

- O-ring for the water separator of common rail type engines

(d) Please use only biodiesel fuel that is appropriate to the intended operation environment of the engines. This especially applies if the operating ambient temperature falls below 0 degree centigrade.

(e) In particular, operation with biodiesel requires daily maintenance as follows:

1. Please daily check the engine oil level. If the oil level rises above the oil level of the previous day, the engine oil needs to be immediately replaced.
2. Please daily check the water level of the water separator. If the water level rises above the "max" indicator, an immediate drain of the water separator is required.

(f) Biodiesel blends up to B20 can only be used for a limited time of up to 3 months of the date of biodiesel manufacture. Therefore biodiesel needs to be used at latest within 2 months from the time of filling the tank or within 3 months from the time of production by the fuel supplier, whichever comes first.

(g) Before a long-term storage without operating the engine, the biodiesel needs to be drained out completely and the engine has to be run for 30 minutes with conventional diesel fuel as indicated in your operation manual.

The summary of difference for operation condition by blends and models which is mentioned above are as follows.

Blends	Service interval	Parts exchange	Model
- B7	Same as standard	Not required	TNV Tier4 CR
B8 - B10	Half of standard	Not required	
B11 - B20	Half of standard	Required (O-ring of water separator only)	

Standard: Same as when using the diesel oil
CR: Common rail type engine

Filling the Fuel Tank

DANGER

Fire and Explosion Hazard!



- Diesel fuel is flammable and explosive under certain conditions.

- Only fill the fuel tank with diesel fuel. Filling the fuel tank with gasoline may result in a fire and will damage the engine.
- Never refuel with the engine running.
- Wipe up all spills immediately.
- Keep sparks, open flames or any other form of ignition (match, cigarette, static electric source) well away when refueling.
- Never overfill the fuel tank.
- Fill the fuel tank. Store any containers containing fuel in a well-ventilated area, away from any combustibles or sources of ignition.
- Be sure to place the diesel fuel container on the ground when transferring the diesel fuel from the pump to the container. Hold the hose nozzle firmly against the side of the container while filling it. This prevents static electricity buildup which could cause sparks and ignite fuel vapors.
- Never place diesel fuel or other flammable material such as oil, hay or dried grass close to the engine during engine operation or shortly after shutdown.
- Before you operate the engine, check for fuel leaks. Replace rubberized fuel hoses every two years or every 2000 hours of engine operation, whichever comes first, even if the engine has been out of service. Rubberized fuel lines tend to dry out and become brittle after two years or 2000 hours of engine operation, whichever comes first.
- Failure to comply will result in death or serious injury.

NOTICE

- Poor quality fuel can reduce engine performance and cause damage. Only use diesel fuels recommended by YANMAR for the best engine performance. The recommended fuel complies with the U.S. EPA and ARB protection guidelines.
- The common rail system installed as this engine's fuel injection device is very high in pressure and sprays fuel into the cylinder. If any impurities or water mixes into the fuel, the sliding parts of the fuel system causes friction and may degrade the engine's exhaust gas property durability. Only use clean diesel fuel.
- Keep the fuel tank and fuel-handling equipment clean at all times. Be careful not to let any contaminants or even dust from the outside into the filler port when supplying fuel.
- Never remove the primary strainer (if equipped) from the fuel tank filler port. If removed, dirt and debris could get into the fuel system causing it to clog.

Note that a typical fuel tank is shown. The fuel tank on your equipment may be different.

1. Clean the area around the fuel cap (1, **Figure 1**).
2. Remove the fuel cap from the fuel tank (2, **Figure 1**).
3. Observe the fuel level sight gauge (3, **Figure 1**) and stop filling when gauge shows fuel tank is full. Never overfill the fuel tank.
4. Replace the fuel cap (1, **Figure 1**), hand tighten. Over tightening the fuel cap will damage it.

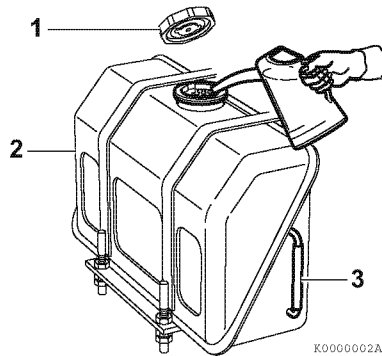

Figure 1

NOTICE

Check the fuel level gauge in the fuel tank daily and ensure that the engine does not run out of fuel. Seizure to the supply pump may occur.

Priming the Fuel System

⚠ DANGER

Fire and Explosion Hazard!



- Diesel fuel is flammable and explosive under certain conditions.

- If the unit has an electric fuel pump, when you prime the fuel system, turn the key switch to the ON position for 10 to 15 seconds to allow the electric fuel pump to prime the system.
- Never open the air vent valve while the fuel system is being primed. The fuel filter has an internal air bleed port.
- Failure to comply will result in death or serious injury.

The fuel system needs to be primed under certain conditions:

- Before starting the engine for the first time.
- After running out of fuel and fuel has been added to the fuel tank.
- After fuel system maintenance such as changing the fuel filter and draining the water separator, or replacing a fuel system component.

To prime the fuel system:

1. Turn the key to the ON position for 10 to 15 seconds. This will allow the electric fuel pump to prime the fuel system.
2. Never use the starter motor to crank the engine in order to prime the fuel system. This may cause the starter motor to overheat and damage the coils, pinion and/or ring gear.

NOTICE

Be sure to perform priming. If air is mixed to the fuel, seizure to the supply pump and the injector may result.

ENGINE LUBRICATING OIL

NOTICE

- Only use the engine lubricating oil specified. Other engine lubricating oils may affect warranty coverage, cause internal engine components to seize and/or shorten engine life.
- Prevent dirt and debris from contaminating the engine lubricating oil. Carefully clean the oil cap/dipstick and the surrounding area before you remove the cap.
- Never mix different types of engine lubricating oil. This may adversely affect the lubricating properties of the engine lubricating oil.
- Never overfill. Overfilling may result in white exhaust smoke, engine overspeed or internal damage.

Engine Lubricating Oil Specifications

Use an engine lubricating oil that meets or exceeds the following guidelines and classifications:

■ Service categories

- API service categories CJ-4
- ACEA service categories E6
- JASO service category DH-2

■ Definitions

- API classification (American Petroleum Institute)
- ACEA classification (Association des Constructeurs Européens d'Automobiles)
- JASO (Japanese Automobile Standards Organization)

NOTICE

- Be sure the engine lubricating oil, engine lubricating oil storage containers, and engine lubricating oil filling equipment are free of sediments and water.
- Change the engine lubricating oil at every 500 hours or 1 year. However, change interval has different standard dependent on the application or engine lubricating oil capacity. Refer to the operation manual provided by the driven machine manufacturer for the actual engine lubricating oil change interval.
- Select the oil viscosity based on the ambient temperature where the engine is being operated. See the SAE service grade viscosity chart (**Figure 2**).
- YANMAR does not recommend the use of engine lubricating oil "additives".
- Never mix different brands of lubricating oils.

■ Additional technical engine lubricating oil requirements:

The engine lubricating oil must be changed when the Total Base Number (TBN) has been reduced to 1.0 mgKOH/g. TBN (mgKOH/g) test method; JIS K-201-5.2-2 (HCl), ASTM D4739 (HCl).

Engine Lubricating Oil Viscosity

Select the appropriate engine lubricating oil viscosity based on the ambient temperature and use the SAE service grade viscosity chart in **Figure 2**.

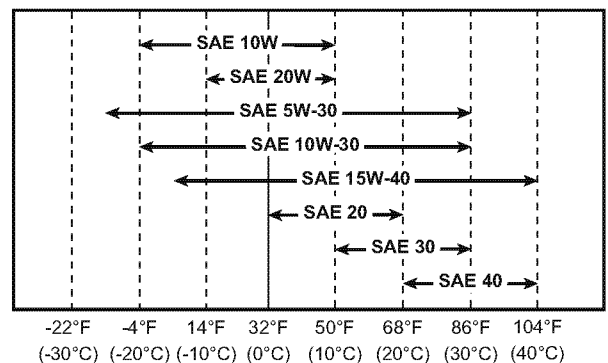

075177-00X00

Figure 2

BEFORE YOU OPERATE

Checking Engine Lubricating Oil

1. Make sure engine is level.
2. Remove dipstick (1, **Figure 3**) and wipe with clean cloth.
3. Fully reinsert dipstick.
4. Remove dipstick. The oil level should be between upper (2, **Figure 3**) and lower (3, **Figure 3**) lines on the dipstick.
5. Fully reinsert dipstick.

Adding Engine Lubricating Oil

1. Make sure engine is level.
2. Remove oil cap (4, **Figure 3**).
3. Add indicated amount of engine lubricating oil at the top or side engine lubricating oil filler port (5, **Figure 3**).
Gradually fill with engine lubricating oil when filling from the filler port on the bonnet. Fill with 1.2 liters or less of engine lubricating oil in 30 seconds or more. Engine lubricating oil may enter the crankshaft and combustion chamber, causing oil hammer and resulting in engine damage.
4. Wait three minutes and check oil level.
5. Add more oil if necessary.
6. Reinstall oil cap (4, **Figure 3**) and hand-tighten. Over-tightening may damage the cap.

Engine Lubricating Oil Capacity (Typical)

These are the engine lubricating oil capacities associated with a “Deep Standard” oil pan. Oil capacity will vary dependent upon which optional oil pan is used. Refer to the operation manual provided by the driven machine manufacturer for the actual engine lubricating oil capacity of your machine.

The following are the engine lubricating oil capacities for various YANMAR TNV engines.

Engine model	Dipstick upper limit/lower limit
3TNV88C, 3TNV86CT, 3TNV86CHT	7.1/4.1 qt (6.7/3.9 L)
4TNV88C, 4TNV86CT, 4TNV86CHT	7.8/4.2 qt (7.4/4.0 L)
4TNV98C, 4TNV98CT	11.1/6.3 qt (10.5/6.0 L)
4TNV94CHT	13.3/8.6 qt (12.6/8.1 L)

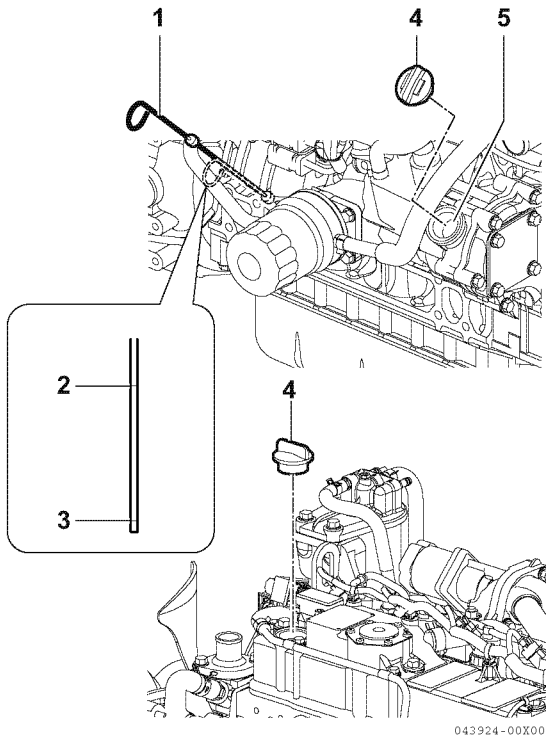

Figure 3

ENGINE COOLANT

⚠ DANGER

Scald Hazard!



- Never remove the radiator cap if the engine is hot. Steam and hot engine coolant will spurt out and seriously burn you. Allow the engine to cool down before you attempt to remove the radiator cap.
- Tighten the radiator cap securely after you check the radiator. Steam can spurt out during engine operation if the cap is loose.
- Always check the level of the engine coolant by observing the reserve tank.
- Failure to comply will result in death or serious injury.

⚠ WARNING

Burn Hazard!



- If you drain the engine oil while it is still hot, stay clear of the hot engine oil to avoid being burned. Always wear eye protection when you handle the engine coolant.
- Failure to comply could result in death or serious injury.

⚠ CAUTION

Engine Coolant Hazard!

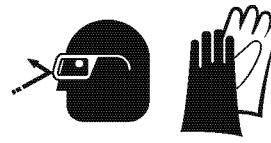

- Wear eye protection and rubber gloves when you handle long life or extended life engine coolant. If contact with the eyes or skin should occur, flush eyes and wash immediately with clean water.
- Failure to comply may result in minor or moderate injury.

NOTICE

- Only use the engine coolant specified. Other engine coolants may affect warranty coverage, cause an internal buildup of rust and scale and/or shorten engine life.
- Prevent dirt and debris from contaminating the engine coolant. Carefully clean the radiator cap and the surrounding area before you remove the cap.
- Never mix different types of engine coolants. This may adversely affect the properties of the engine coolant.

BEFORE YOU OPERATE

Engine Coolant Specifications

Use a Long Life Coolant (LLC) or an Extended Life Coolant (ELC) that meets or exceeds the following guidelines and specifications.

- ASTM D6210, D4985 (US)
- JIS K-2234 (Japan)
- SAE J814C, J1941, J1034 or J2036 (International)

■ Alternative engine coolant

If an Extended or Long Life Coolant is not available, alternatively, you may use an ethylene glycol or propylene glycol based conventional coolant (green).

NOTICE

- Always use a mix of coolant and water. Never use water only.
- Mix coolant and water per the mixing instructions on the coolant container.
- Water quality is important to coolant performance. YANMAR recommends that soft, distilled or demineralized water be used to mix with coolants.
- Never mix extended or long life coolants and conventional (green) coolants.
- Never mix different types and/or colors of extended life coolants.
- Replace the coolant every 2000 engine hours or two years.

Filling Radiator with Engine Coolant

Fill the radiator and reserve tank as follows. This procedure is for filling the radiator for the first time or refilling it after it is flushed. Note that a typical radiator is illustrated.

1. Check to be sure the radiator drain plug is installed and tightened or the drain valve (1, **Figure 4**) is closed. Also make sure the coolant hoses (1, **Figure 5**) are installed at the oil cooler.

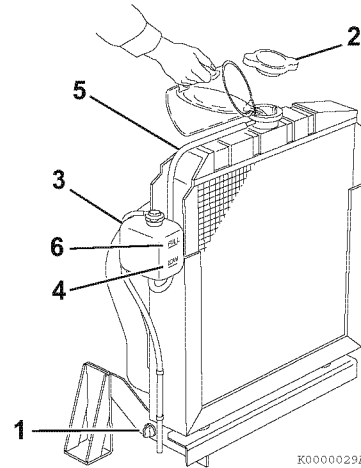

Figure 4

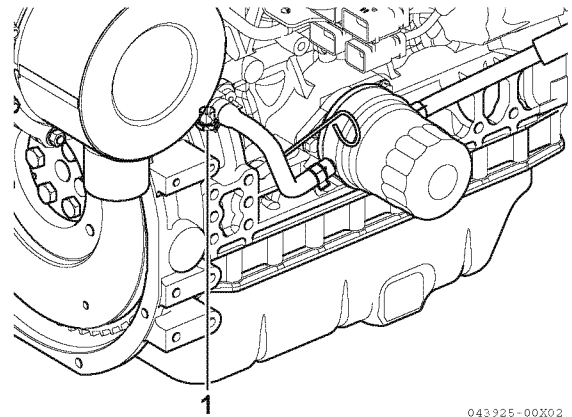

Figure 5

2. Remove the radiator cap (1, **Figure 4**) by turning it counterclockwise about 1/3 of a turn.
3. Pour the engine coolant slowly into the radiator until it is even with the lip of the engine coolant filler port. Make sure that air bubbles do not develop as you fill the radiator.
4. Reinstall the radiator cap (2, **Figure 4**). Align the tabs on the back side of the radiator cap with the notches on the engine coolant filler port. Press down and turn the cap clockwise about 1/3 of a turn.
5. Remove the cap of the reserve tank (3, **Figure 4**), and fill it to the LOW (COLD) mark (4, **Figure 4**) with engine coolant. Reinstall the cap.
6. Check the hose (5, **Figure 4**) that connects the reserve tank (3, **Figure 4**) to the radiator. Be sure it is securely connected and there are no cracks or damage. If the hose is damaged, engine coolant will leak out instead of going into the reserve tank.
7. Run the engine until it reaches operating temperature. Check the level of engine coolant in the reserve tank. When the engine is running and the engine coolant is at normal temperature, the coolant level in the reserve tank should be at or near the FULL (HOT) mark (6, **Figure 4**). If the coolant is not at the FULL (HOT) mark, add coolant to the reserve tank to bring the coolant level to the FULL (HOT) mark.

Daily Check of the Cooling System

1. Check the level of engine coolant in the reserve tank. When the engine is cold, the coolant level in the tank should be at or slightly above the LOW (COLD) mark (4, **Figure 4**) on the coolant reserve tank.

If the coolant level is at the FULL (HOT) mark (6, **Figure 4**) when the engine is cold, the coolant will expand when it becomes hot and possibly spray out of the overflow hose.
2. Add additional engine coolant to the reserve tank if necessary.
3. Check the radiator hoses for cracks, abrasions, cuts or other damage. Replace as necessary.

Engine Coolant Capacity (Typical)

Capacities listed are for the engine only without a radiator. Refer to the operation manual provided by the driven machine manufacturer for actual engine coolant capacity on your machine.

The following are the engine coolant capacities for various YANMAR TNV engines.

Engine model	Engine coolant capacity
3TNV88C, 3TNV86CT, 3TNV86CHT	2.1 qt (2.0 L)
4TNV88C, 4TNV86CT, 4TNV86CHT	2.9 qt (2.7 L)
4TNV98C, 4TNV98CT, 4TNV94CHT	4.4 qt (4.2 L)

BEFORE YOU OPERATE

DAILY CHECKS

Before you begin any job, make sure the YANMAR TNV engine is in good operating condition. Make sure you check the following items before you start your shift and have any repairs completed before you start work.

WARNING

High-Pressure Hazard!



- If fuel is spraying out or leaking from broken fuel system such as high-pressure fuel injection lines, it may be in high-pressure. Avoid skin contact. High-pressure fuel can penetrate your skin and result in serious injury. If you are exposed to high-pressure fuel spray, obtain prompt medical treatment.

- Have your YANMAR dealer or distributor repair the damage.
- Failure to comply could result in death or serious injury.

NOTICE

Make it a habit to perform daily checks. See *Daily Checks in the Before You Operate Section of this manual.*

Periodic maintenance prevents unexpected downtime, reduces the number of accidents due to poor machine performance and helps extend the life of the engine.

Visual Checks

1. Check for engine lubricating oil leaks.
2. Check for fuel leaks.
3. Check for engine coolant leaks.
4. Check for damaged or missing parts.
5. Check for loose, missing or damaged fasteners.
6. Check the electrical harnesses for cracks, abrasions, and damaged or corroded connectors.
7. Check hoses for cracks, abrasions, and damaged, loose or corroded clamps.
8. Check and clean radiator fins as necessary. See *Check and clean radiator fins on page 77.*

9. Check the water separator for presence of water and contaminants. If you find any water or contaminants, drain the water separator. See *Drain water separator on page 74.* If you have to drain the water separator frequently, drain the fuel tank and check for the presence of water in your fuel supply. See *Drain fuel tank on page 76.*

NOTICE

- If any problem is noted during the visual check, the necessary corrective action should be taken before you operate the engine.
- Be sure to check water in the water separator daily. The fuel system in the common rail system is extremely high-pressured. If water is mixed to the supplied fuel in the supply pump, seizure to the supply pump and the injector may result.

Check Diesel Fuel, Engine Lubricating Oil and Engine Coolant Levels

Follow the procedures in *Diesel Fuel on page 48*, *Engine Lubricating Oil on page 53* and *Engine Coolant on page 55* to check these levels.

Check Engine Speed Control

Check the engine speed control for smooth operation.

Check Operator's Console

Before you operate the engine you should make sure that all of the indicators are functioning properly.

The indicators that are located on a typical operator's console are shown as examples below and in **Figure 6**. Refer to the operation manual provided by the manufacturer of the driven machine since the indication may differ by each machine.

Turning the key switch ON will light the following warning indicator for two seconds, and then it turns off. If it stays on or blinks, contact your nearest YANMAR dealer or distributor.

- 1 Preheat indicator**
- 2 Lubricating oil pressure indicator**
- 3 Coolant temperature indicator**
- 4 Battery charge indicator**
- 5 DPF regeneration request lamp**
- 6 Exhaust gas temperature lamp**
- 7 DPF regeneration approval lamp**
- 8 DPF regeneration inhibit lamp**
- 9 Engine failure lamp**

Meanings and functions of each warning indicator are described in *page 40* and *page 60*.

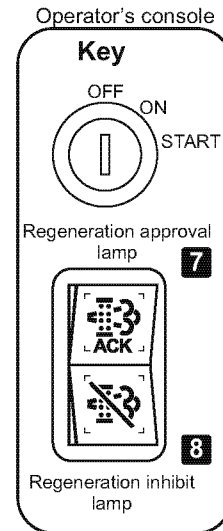
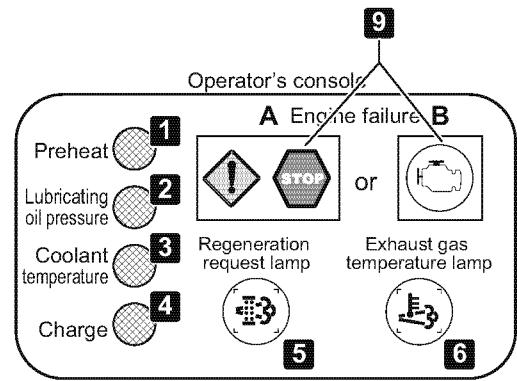



062022-00EN01

Figure 6

BEFORE YOU OPERATE

Here is a summary of how these indicators function.

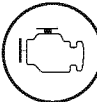
Alarm lamp	Turns the key switch OFF and ON	After engine start-up	Failure alarm	
Preheat indicator	Goes out after 1 to 15 seconds, depending on the coolant temperature.	Goes out	-	
Lubricating oil pressure indicator (Engine oil alarm)	Lit	Goes out when the engine oil pressure becomes within the normal range.	Comes on if the lubricating system fails.	
Coolant temperature indicator (Coolant temperature alarm)	Comes on momentarily, then goes out.	-	Comes on if the engine coolant overheats.	
Battery charge indicator	Lit	Goes out when the alternator starts charging power to the battery.	Comes on if the charging system fails.	
DPF regeneration request lamp	Comes on for 2 seconds, and then goes out.	-	<ul style="list-style-type: none"> Comes on if stationary regeneration is required. Goes out when stationary regeneration starts after pushing the DPF regeneration request switch. 	
Exhaust temperature alarm lamp	Comes on for 2 seconds, and then goes out.	-	Comes on during reset regeneration and stationary regeneration. Goes out when those regenerations are complete.	
DPF regeneration approval lamp	Comes on for 2 seconds, and then goes out.	-	<ul style="list-style-type: none"> Flashes during stand-by before stationary regeneration. Comes on when stationary regeneration starts. Goes out when regeneration is complete. 	
DPF regeneration inhibit lamp	Comes on for 2 seconds, and then goes out.	-	Comes on when the DPF regeneration inhibit switch is turned to "Regeneration Inhibited".	
Engine failure lamp	Comes on for 2 seconds, and then goes out.	-	Amber warning lamp 	<ol style="list-style-type: none"> Comes on when engine faults are detected. Flashes when stationary regeneration or ash cleaning (Level 1) is required.
		-	Engine stop lamp 	<ol style="list-style-type: none"> Comes on when severe engine failures are detected. Flashes when ash cleaning (Level 2) is required.
		-	Fault indicator lamp 	<ol style="list-style-type: none"> Comes on when engine faults are detected. Comes on when stationary regeneration or ash cleaning is required.

ENGINE OPERATION

This section of the Operation Manual describes the procedures for starting the engine, checking engine performance during operation, and shutting the engine down.

STARTING ENGINE

WARNING

Sudden Movement Hazard!

- Engaging the transmission or PTO at an elevated engine speed could result in unexpected movement of the equipment.
- Failure to comply could result in death or serious injury.

Use the following procedure to start the engine. Note that two typical operator's consoles are shown for illustrative purposes only.

1. Make sure you follow the procedures stated in the *Daily Checks* on page 58.
2. Make sure the water separator fuel valve (1, **Figure 1**) is in the ON position (2, **Figure 1**).

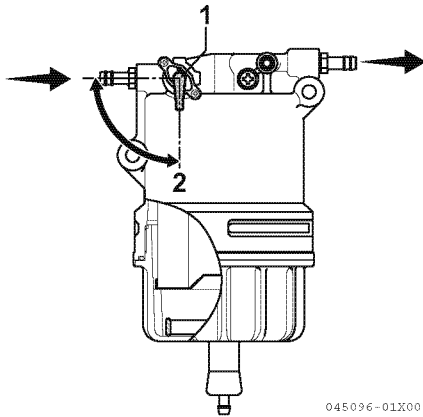

Figure 1

3. Set the transmission (if equipped) of the driven machine to the NEUTRAL position.
4. Disengage the PTO (if equipped).
5. Set the engine speed control to the mid-position.

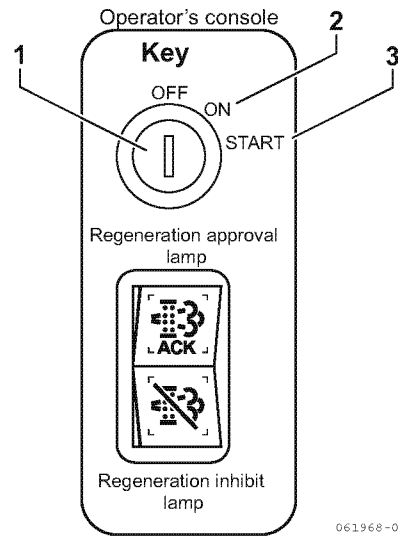
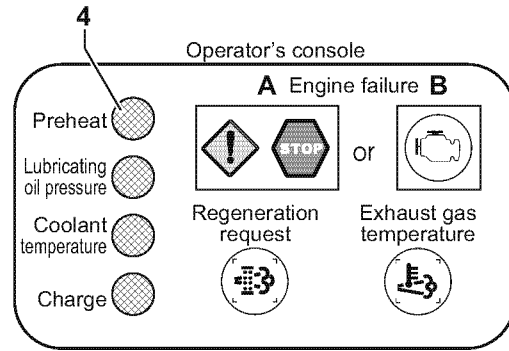

Figure 2

NOTICE

Never use an engine starting aid such as ether. Engine damage will result.

6. Insert the key to the key switch (1, **Figure 2**).
7. Turn the key to the ON position (2, **Figure 2**). The preheat indicator (4, **Figure 2**) comes on and goes out after few seconds. After the preheat indicator goes out, you can start the engine.

Note: The glow plugs are used to assist starting in cold weather conditions. When the key switch is set to the ON position, the system automatically energizes the glow plug relay and keeps it energized for a particular amount of time, depending on the cooling water temperature. During energization, the preheat indicator comes on. If you are operating your engine in normal or warm weather conditions, this procedure is not required.

NOTICE

Be sure to perform priming the engine before starting. When you restart the engine after engine stall, turn the key switch to the ON position first to allow the electric fuel pump to prime the fuel system. After priming, turn the key switch to the START position to start the engine. Never hold the key in the START position too long without priming the engine or the starter motor will overheat. In addition, seizure to the supply pump and the injector may occur if air is mixed to the fuel.

8. Turn the key clockwise to the START position (3, **Figure 2**). Release the key as soon as the engine starts. It will return to the ON position (2, **Figure 2**).

NOTICE

Never hold the key in the START position for longer than 15 seconds or the starter motor will overheat.

9. If the engine fails to start:

- 1- Wait until the engine comes to a complete stop before you attempt to start it again.

Note: Some key switches are equipped with an interlock that will not allow you to re-engage the starter without first turning the key to the OFF position.

NOTICE

Engaging the starter while the engine is still rotating will result in damage to the starter and flywheel.

- 2- Wait at least 30 seconds before you attempt to start the engine again. This procedure will allow the battery voltage to recover and prevent damage to the starter motor due to the low battery voltage.

CHECKING THE ENGINE DURING OPERATION

WARNING

High-Pressure Hazard!



- While the engine is running or right after the engine has stopped, there is still high-pressure fuel left in the fuel piping system. When you need to disassemble the fuel system, wait for 10 to 15 minutes after stopping the engine.
- If fuel is spraying out or leaking from broken fuel system such as high-pressure fuel injection lines, it may be in high-pressure. Avoid skin contact. High-pressure fuel can penetrate your skin and result in serious injury. If you are exposed to high-pressure fuel spray, obtain prompt medical treatment.
- Disassembling or repairing the fuel system shall be done by professionals such as the authorized YANMAR distributor or dealer.
- Failure to comply could result in death or serious injury.

NOTICE

Make sure the engine is installed on a level surface. If a continuously running engine is installed at an angle greater than 30° in any direction or if an engine runs for short periods of time (less than three minutes) at an angle greater than 35° in any direction, engine oil may enter the combustion chamber causing excessive engine speed and white exhaust smoke. This may cause serious engine damage.

NOTICE

New engine break-in:

- On the initial engine start-up, allow the engine to idle for approximately 15 minutes while you check for proper engine oil pressure, diesel fuel leaks, engine oil leaks, coolant leaks, and for proper operation of the indicators and/or gauges.
- During the first hour of operation, vary the engine speed and the load on the engine. Short periods of maximum engine speed and load are desirable. Avoid prolonged operation at minimum or maximum engine speeds and loads for the next four to five hours.
- During the break-in period, carefully observe the engine lubricating oil pressure and engine coolant temperature.
- During the break-in period, check the engine lubricating oil and coolant levels frequently.

NOTICE

Never engage the starter motor while the engine is running. This may damage the starter motor pinion and/or ring gear.

1. While the engine is running, check the gauges for normal indications. The gauges shown in **Figure 3** are provided for illustrative purposes only.

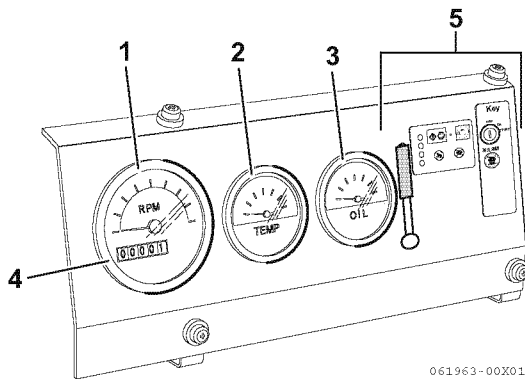

Figure 3

- **Tachometer (1, Figure 3)**
Make sure the engine speed is within normal limits.
- **Engine lubricating oil pressure (2, Figure 3)**
Make sure the engine oil pressure is within normal limits. *See Principal Engine Specifications on page 103.*
- **Engine coolant temperature (3, Figure 3)**
Make sure the engine coolant temperature is within normal limits.
- **Hour meter (4, Figure 3)**
The hour meter display shows the total number of hours the engine has run. This is useful for planning periodic maintenance operations. *See Periodic Maintenance Schedule on page 70.*
If any of the gauges shows an out of normal limits condition, shut down the engine and have the necessary repairs performed.

2. After the engine has reached operating temperature, all of the indicators (5, **Figure 3**) should be off. If any of the indicators are on, shut down the engine and have the necessary repairs performed.
3. Check for any fuel, engine coolant or engine lubricating oil leaks. If any leaks are found shut down the engine and have the necessary repairs performed.
4. Check for abnormal sounds or vibration. In some applications the engine and its mounting may start to resonate and cause unusual vibrations at certain engine speeds. Avoid running the engine at these speeds. If the abnormal sounds or vibration cannot be resolved, shut down the engine and have the necessary repairs performed. Contact your authorized YANMAR industrial engine dealer or distributor.
5. Check for white or black smoke from the exhaust system. A small amount of white exhaust smoke is normal on start-up of a cold engine. Black exhaust smoke could mean the engine is overloaded or is being over-fueled. If either of these conditions persists, contact your authorized YANMAR industrial engine dealer or distributor.
6. If there is a problem with the engine and/or its control components, the engine fault indicator comes on and indicates the status. If the engine fault indicator illuminates during engine operation, stop the engine immediately. Do not keep running the engine while the fault indicator is on. It will not only void the engine warranty, but could result in a serious malfunction of or damage to the engine. Determine the cause and repair the problem before you continue to operate the engine.
7. Check the fuel level during operation. If the fuel level runs low, stop the engine and refuel.

SHUTTING DOWN THE ENGINE

NOTICE

For maximum engine life, YANMAR recommends that when shutting the engine down, you allow the engine to idle, without load, for five minutes. This will allow the engine components that operate at high temperatures, such as the turbocharger (if equipped) and exhaust system, to cool slightly before the engine itself is shut down.

Follow these steps to shut down the engine:

1. Disengage the PTO and/or set the transmission to NEUTRAL (if equipped).
2. Set the engine speed control to its lowest setting.
3. Run the engine at low idle speed for at least five minutes before you shut it down.

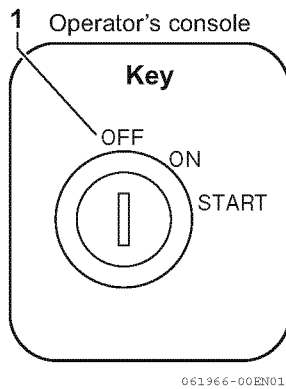

Figure 4

4. Turn the key to the OFF position (1, **Figure 4**) and remove it from the key switch.
5. If the engine will not be used for six months or longer, follow the additional instructions in *Long-Term Storage on page 97*.

PERIODIC MAINTENANCE

This section of the Operation Manual describes the procedures for proper care and maintenance of the engine.

PRECAUTIONS

The Importance of Periodic Maintenance

Engine deterioration and wear occurs in proportion to length of time the engine has been in service and the conditions the engine is subject to during operation. Periodic maintenance prevents unexpected downtime, reduces the number of accidents due to poor machine performance and helps extend the life of the engine.

Performing Periodic Maintenance

WARNING

Exhaust Hazard!



- **Never operate the engine in an enclosed area such as a garage, tunnel, underground room, manhole or ship's hold without proper ventilation.**
- **Never block windows, vents, or other means of ventilation if the engine is operating in an enclosed area. All internal combustion engines create carbon monoxide gas during operation. Accumulation of this gas within an enclosure could cause illness or even death.**
- **Make sure that all connections are tightened to specifications after repair is made to the exhaust system.**
- **Failure to comply could result in death or serious injury.**

Perform periodic maintenance procedures in an open, level area free from traffic. If possible, perform the procedures indoors to prevent environmental conditions, such as rain, wind, or snow, from damaging the machine.

The Importance of Daily Checks

Periodic Maintenance Schedules assume that the daily checks are performed on a regular basis. Make it a habit of performing daily checks before the start of each shift. *See Daily Checks on page 58.*

Keep a Log of Engine Hours and Daily Checks

Keep a log of the number of hours the engine is run each day and a log of the daily checks performed. Also note the date, type of repair (e.g., replaced alternator), and parts needed for any service needed between the periodic maintenance intervals. Periodic maintenance intervals are every 50, 250, 500, 1000, 1500, 2000 and 3000 engine hours. Failure to perform periodic maintenance will shorten the life of the engine.

YANMAR Replacement Parts

YANMAR recommends that you use genuine YANMAR parts when replacement parts are needed. Genuine replacement parts help ensure long engine life.

Tools Required

Before you start any periodic maintenance procedure make sure you have the tools you need to perform all of the required tasks.

Ask Your Authorized YANMAR Industrial Engine Dealer or Distributor for Help

Our professional service technicians have the expertise and skills to help you with any maintenance or service related procedures you need help with.

Required EPA/ARB Maintenance USA Only

To maintain optimum engine performance and compliance with the Environmental Protection Agency (EPA) Regulations Non-Road Engines and the California Air Resources Board (ARB, California), it is essential that you follow the *Periodic Maintenance Schedule on page 70* and *Periodic Maintenance Procedures on page 72*.

EPA/ARB Installation Requirements USA Only

The following are the installation requirements for the EPA/ARB. Unless these requirements are met, the exhaust gas emissions will not be within the limits specified by the EPA and ARB.

Therefore, periodically perform the maintenance and cleaning of air cleaner and muffler.

Maximum Exhaust Gas Restriction shall be:

Initial upper limit	12.7 kPa (1300 mmAq)
Cleaning upper limit	45 kPa (4590 mmAq)

Maximum air intake restriction shall be 0.90 psi (6.23 kPa; 635 mmAq) or less. Clean or replace the air cleaner element if the air intake restriction exceeds the above mentioned value.

STANDARD TORQUE CHART

Thread size x pitch	mm	M6 x 1.0	M8 x 1.25	M10 x 1.5	M12 x 1.75	M14 x 1.5	M16 x 1.5
Tightening torque	in.-lb	96.0 ± 9.0	–	–	–	–	–
	ft-lb	–	19.0 ± 2.0	36.0 ± 4.0	65.0 ± 7.0	101.0 ± 7.0	167.0 ± 7.0
	N·m	10.8 ± 1.0	25.5 ± 2.9	49.0 ± 4.9	88.3 ± 9.8	137.0 ± 9.8	226.0 ± 9.8
	kgf·m	1.1 ± 0.1	2.6 ± 0.3	5.0 ± 0.5	9.0 ± 1.0	14.0 ± 1.5	23.0 ± 2.0

Note: Torque values shown in this manual are for clean, non-lubricated fasteners unless otherwise specified.

Tightening Fasteners

Use the correct amount of torque when you tighten fasteners on the machine. Applying excessive torque may damage the fastener or component and not enough torque may cause a leak or component failure.

NOTICE

The tightening torque in the *Standard Torque Chart in the Periodic Maintenance Section of this manual* should be applied only to the bolts with a “7” head. (JIS strength classification: 7T)

- Apply 60 % torque to bolts that are not listed.
- Apply 80 % torque when tightened to aluminum alloy.



PERIODIC MAINTENANCE

PERIODIC MAINTENANCE SCHEDULE

Daily and periodic maintenance is important to keep the engine in good operating condition. The following is a summary of maintenance items by periodic maintenance intervals. Periodic maintenance intervals vary depending on engine application, loads, diesel fuel and engine oil used and are hard to establish definitively. The following should be treated only as a general guideline.

NOTICE

Establish a periodic maintenance plan according to the engine application and make sure you perform the required periodic maintenance at intervals indicated. Failure to follow these guidelines will impair the engine's safety and performance characteristics, shorten the engine's life and may affect the warranty coverage on your engine. See *YANMAR Limited Warranty in the Warranty Section of this manual*.

It is recommended to perform water-bleeding of the oil/water separator in particular daily. Protect the supply pump and the injector from seizure.

The TNV series engines may inject fuel after general combustion (post-injection) for the purpose of self-regeneration of the DPF. This fuel may enter the oil pan through the cylinder and dilute the engine oil. Check the oil level daily. If it is above the upper limit of the dipstick, change the oil regardless of the replacement intervals.

Add the new oil if the oil level is below lower mark on the dipstick to keep the oil level between upper and lower mark, even if it is remaining the change interval.

Consult your authorized YANMAR industrial engine dealer or distributor for assistance when checking items marked with a ●.

Periodic Maintenance Chart

○: Check ◇: Replace ●: Contact your authorized YANMAR industrial engine dealer or distributor

System	Check item	Daily	Periodic maintenance interval						
			Every 50 hours	Every 250 hours	Every 500 hours	Every 1000 hours	Every 1500 hours	Every 2000 hours	Every 3000 hours
Cooling system	Check and refill engine coolant	○							
	Check and clean radiator fins			○					
	Check and adjust cooling fan V-belt		○ 1st time	○ 2nd and after					
	Change coolant							◇ or every 2 years*1	
Cylinder head	Check and adjust intake/exhaust valve clearance					●			
Electrical equipment	Check indicators	○							
	Inspect ECU and related sensors and actuators								●
	Check battery		○						
Engine lubricating oil	Check engine lubricating oil level	○							
	Drain and fill engine lubricating oil					◇ or every 1 year*2			
	Replace engine lubricating oil filter								

PERIODIC MAINTENANCE

○: Check ◇: Replace ●: Contact your authorized YANMAR industrial engine dealer or distributor

System	Check item	Daily	Periodic maintenance interval						
			Every 50 hours	Every 250 hours	Every 500 hours	Every 1000 hours	Every 1500 hours	Every 2000 hours	Every 3000 hours
Emission control warranty	Inspect turbocharger (blower wash as necessary)								●
	Inspect, clean and test EGR valve (except for engines with turbochargers)								●
	Clean EGR cooler (clean to blow water/air passages)								●
	Inspect crankcase breather system						●		
	Inspect DPF DOC								●
	Check and clean of DPF soot filter *3								
	Inspect and test intake throttle valve								●
	Inspect and test exhaust throttle valve *4								●
Fuel	Check and refill fuel tank level	○							
	Drain fuel tank			○					
	Drain water separator		○						
	Check fuel filter, water separator	○							
	Replace fuel filter, water separator element				◇				
	Check and clean injector								○
Hoses	Inspect and replace fuel line, coolant line, lubricating oil line, and breather hose							◇ or every 2 years*1	
Intake and exhaust	Clean or replace air cleaner element			○	◇				
Complete engine	Overall visual check daily	○							

*1: Whichever occurs first.

*2: Differ depending on the application or engine oil capacity.

If the engine is equipped with a shallow type oil sump, the maintenance interval should be every 250 hours regardless of the implement.

*3: If your engine is equipped with DPF cleaning alarm, clean the DPF when the alarm lamp comes on.

If your engine is not equipped with DPF cleaning alarm, clean the DPF on 6000 hours of operation.

*4: If your engine is equipped with exhaust throttle valve.

Note: These procedures are considered normal maintenance and are performed at the owner's expense.

PERIODIC MAINTENANCE PROCEDURES

After Initial 50 Hours of Operation

Perform the following maintenance after the initial 50 hours of operation.

- Check and adjust cooling fan V-belt

WARNING

Sudden Movement Hazard!

- Engaging the transmission or PTO at an elevated engine speed could result in unexpected movement of the equipment.
- Failure to comply could result in death or serious injury.

Check and adjust cooling fan V-belt

The V-belt will slip if it does not have the proper tension. This will prevent the alternator from generating sufficient power. Also, the engine will overheat due to the engine coolant pump pulley slipping.

Check and adjust the V-belt tension (deflection) as follows:

1. Press the V-belt down with your thumb with a force of approximately 22 ft-lb (98 N·m, 10 kgf·m) to check the deflection.

There are three positions to check for V-belt tension (**Figure 1, (A), (B) and (C)**). You can check the tension at whichever position is the most accessible. The proper deflection of a used V-belt at each position is:

Used V-belt tension		
A	B	C
3/8 - 1/2 in. (10 - 14 mm)	1/4 - 3/8 in. (7 - 10 mm)	5/16 - 1/2 in. (9 - 13 mm)

Note: A "Used V-Belt" refers to a V-belt which has been used on a running engine for five minutes or more.

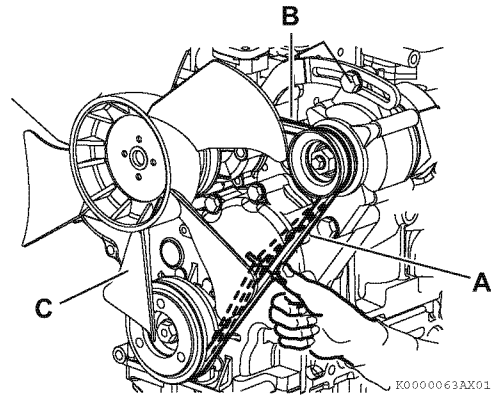

Figure 1

2. If necessary, adjust the V-belt tension.

Manual type

Loosen the adjusting bolt (1, **Figure 2**) and the other related bolts and/or nuts, then move the alternator (2, **Figure 2**) with a pry bar (3, **Figure 2**) to tighten the V-belt to the desired tension. Then tighten the adjusting bolts and/or nuts.

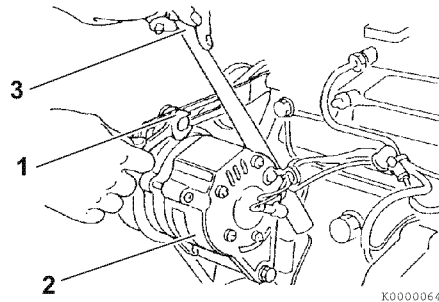

Figure 2

• **Jack type**

- 1- Loosen the attaching nut (1, **Figure 3**) under the alternator, belt adjuster mounting bolt (2, **Figure 3**), and belt adjuster tightening bolt (3, **Figure 3**).
- 2- Loosen the adjuster bolt lock nut (4, **Figure 3**) and adjust the tension by turning the adjuster bolt (5, **Figure 3**). (Turn the adjuster bolt clock wise to stretch the belt.)

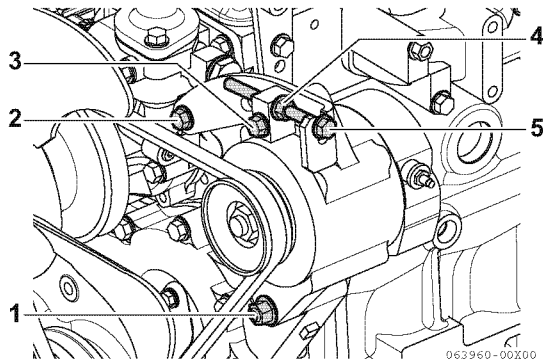

Figure 3

- 3- After adjusting with the adjuster bolt (5, **Figure 3**), in the following order, tighten the tightening bolt (3, **Figure 3**), belt adjuster mounting bolt (2, **Figure 3**), attaching nut (1, **Figure 3**), and then the lock nut (4, **Figure 3**) at last.
3. Tighten the V-belt to the proper tension. There must be clearance (1, **Figure 4**) between the V-belt and the bottom of the pulley groove. If there is no clearance (2, **Figure 4**) between the V-belt and the bottom of the pulley groove, replace the V-belt.

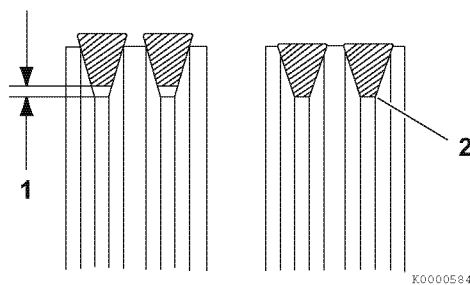

Figure 4

4. Check the V-belt for cracks, oil or wear. If any of these conditions exist, replace the V-belt.
5. Install the new V-belt. Refer to the table for proper tension.

New V-belt tension		
A	B	C
5/16 - 7/16 in. (8 - 12 mm)	3/16 - 5/16 in. (5 - 8 mm)	1/4 - 7/16 in. (7 - 11 mm)

6. After adjusting, run the engine for 5 minutes or more. Check the tension again using the specifications for a used V-belt.

Used V-belt tension		
A	B	C
3/8 - 1/2 in. (10 - 14 mm)	1/4 - 3/8 in. (7 - 10 mm)	5/16 - 1/2 in. (9 - 13 mm)

Every 50 Hours of Operation

After you complete the initial 50 hour maintenance procedures, perform the following procedures every 50 hours thereafter.

- Drain water separator
- Check battery

■ Drain water separator

DANGER

Fire and Explosion Hazard!



- Diesel fuel is flammable and explosive under certain conditions.

- When you remove any fuel system component to perform maintenance (such as changing the fuel filter) place an approved container under the opening to catch the fuel.
- Never use a shop rag to catch the fuel. Vapors from the rag are flammable and explosive.
- Wipe up any spills immediately.
- Wear eye protection. The fuel system is under pressure and fuel could spray out when you remove any fuel system component.
- Failure to comply will result in death or serious injury.

NOTICE

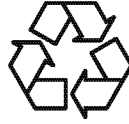

- Be sure to perform periodic maintenance in a clean environment free from dust.

- Always be environmentally responsible.
- Follow the guidelines of the EPA or other governmental agencies for the proper disposal of hazardous materials such as engine oil, diesel fuel and engine coolant. Consult the local authorities or reclamation facility.
- Never dispose of hazardous materials irresponsibly by dumping them into a sewer, on the ground, or into ground water or waterways.
- Failure to follow these procedures may seriously harm the environment.

NOTICE

Check the water in the water separator everyday. The fuel system in the common rail system is extremely high-pressured. If water is mixed into the supplied fuel in the supply pump, it may result in seizure to the supply pump and the injector.

Drain the water separator whenever there are contaminants, such as water, collected in the bottom of the cup. Never wait until the scheduled periodic maintenance if contaminants are discovered.

The cup of the separator is made from semi-transparent material. In the cup is a red colored float ring. The float ring will rise to the surface of the water to show how much needs to be drained. Also, some optional water separators are equipped with a sensor to detect the amount of contaminants. This sensor sends a signal to an indicator to alert the operator.

Drain the water separator as follows:

1. Position an approved container under the water separator (1, **Figure 5**) to collect the contaminants.

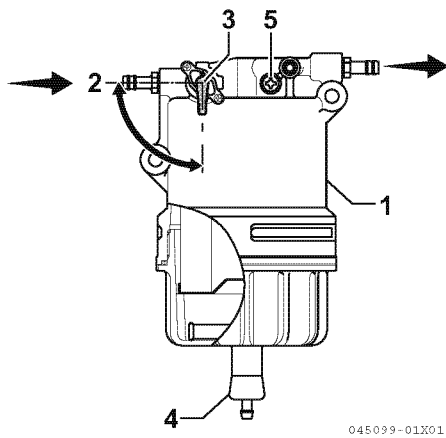

Figure 5

2. Close the fuel valve (3, **Figure 5**) by turning it to (2, **Figure 5**) position.
3. Open the drain valve (4, **Figure 5**) at the bottom of the water separator. Drain any water collected inside. If no water comes out, loosen the air vent screw (5, **Figure 5**) at the top of the water separator by turning it counterclockwise 2 - 3 turns.
4. If still no water comes out, open the fuel valve (3, **Figure 5**).
5. After draining the water separator, hand-tighten the drain valve.

Tightening torque	0.7 - 1.4 ft·lb (1 - 2 N·m; 0.1 - 0.2 kgf·m)
-------------------	---

6. Be sure to tighten the air vent screw if it is loosened.
7. Open the fuel valve.
8. Be sure to prime the diesel fuel system.
See Priming the Fuel System on page 52.
9. Check for fuel leaks.

NOTICE

If the water separator is positioned higher than the fuel level in the fuel tank, water may not drip out when the water separator drain valve is opened. If this happens, turn the air vent screw on the top of the water separator 2 - 3 turns counterclockwise. Be sure to tighten the air vent screw after the water has drained out.

■ Check battery

⚠ DANGER

Explosion Hazard!



- Never short out the battery terminals, including when checking the remaining battery charge. This will result in a spark and may cause an explosion or fire. Use a hydrometer to check the remaining battery charge.
- If the electrolyte is frozen, slowly warm the battery before you recharge it.
- Failure to comply will result in death or serious injury.

⚠ WARNING

Burn Hazard!



- Batteries contain sulfuric acid. Never allow battery fluid to come in contact with clothing, skin or eyes. Severe burns could result. Always wear safety goggles and protective clothing when servicing the battery. If battery fluid contacts the eyes and/or skin, immediately flush the affected area with a large amount of clean water and obtain prompt medical treatment.
- Failure to comply could result in death or serious injury.

NOTICE

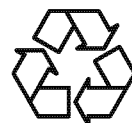

- Always be environmentally responsible.
- Follow the guidelines of the EPA or other governmental agencies for the proper disposal of hazardous materials such as engine oil, diesel fuel and engine coolant. Consult the local authorities or reclamation facility.
- Never dispose of hazardous materials irresponsibly by dumping them into a sewer, on the ground, or into ground water or waterways.
- Failure to follow these procedures may seriously harm the environment.

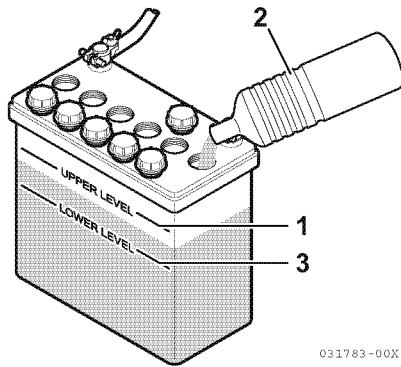

Figure 6

- When the amount of fluid nears the lower limit (3, **Figure 6**), fill with distilled water (2, **Figure 6**) so it is at the upper limit (1, **Figure 6**). If operation continues with insufficient battery fluid, the battery life is shortened, and the battery may overheat and explode. During the summer, check the fluid level more often than specified.
- If the engine cranking speed is so slow that the engine does not start, recharge the battery. Use a specialized battery charger to recharge the battery with a voltage of 8 volts or less. Charging the battery by booster even with a voltage of 8 volts or less will generate an abnormally high voltage and destroy electrical equipment. When unavoidably using a rapid charger to recharge, do not insert and turn the starter key to ON position while the battery is being charged. Avoid using a charger equipped with a boost function (cell start support) to start the engine. The ECU may be damaged by applied excessive voltage.
- If the engine still will not start after charging, have your authorized YANMAR industrial engine dealer or distributor check the battery and the engine's starting system.
- If operating the machine where the ambient temperature could drop to -15 °C (5 °F) or less, remove the battery from the machine at the end of the day. Store the battery in a warm place until the next use. This will help start the engine easily at low ambient temperatures.

Every 250 Hours of Operation

Perform the following maintenance every 250 hours of operation.

- Drain fuel tank
- Check and clean radiator fins
- Check and adjust cooling fan V-belt
- Clean air cleaner element

■ Drain fuel tank

! DANGER

Fire and Explosion Hazard!



- Diesel fuel is flammable and explosive under certain conditions.

- **When you remove any fuel system component to perform maintenance (such as changing the fuel filter) place an approved container under the opening to catch the fuel.**
- **Never use a shop rag to catch the fuel. Vapors from the rag are flammable and explosive.**
- **Wipe up any spills immediately.**
- **Wear eye protection. The fuel system is under pressure and fuel could spray out when you remove any fuel system component.**
- **Failure to comply will result in death or serious injury.**

NOTICE



- Always be environmentally responsible.

- Follow the guidelines of the EPA or other governmental agencies for the proper disposal of hazardous materials such as engine oil, diesel fuel and engine coolant. Consult the local authorities or reclamation facility.
- Never dispose of hazardous materials irresponsibly by dumping them into a sewer, on the ground, or into ground water or waterways.
- Failure to follow these procedures may seriously harm the environment.

Note that a typical fuel tank is illustrated.

1. Position an approved container under the diesel fuel tank (1, **Figure 7**) to collect the contaminants.

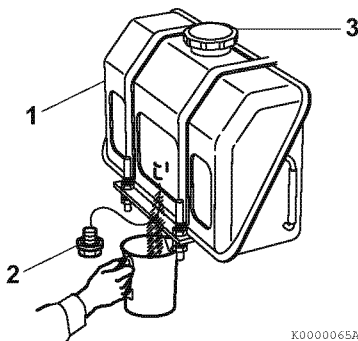

Figure 7

2. Remove the fuel cap (3, **Figure 7**).
3. Remove the drain plug (2, **Figure 7**) to drain the contaminants (water, dirt, etc.) from the bottom of the tank.
4. Drain the tank until clean diesel fuel with no water or dirt flows out. Reinstall and tighten the drain plug firmly.
5. Reinstall the fuel cap.
6. Check for leaks.

NOTICE

Be sure to perform priming. If air is mixed to the fuel, seizure to the supply pump and the injector may result.

■ Check and clean radiator fins

CAUTION

Flying Object Hazard!



- Always wear eye protection when servicing the engine and when using compressed air or high-pressure water. Dust, flying debris, compressed air, pressurized water or steam may injure your eyes.

- Failure to comply may result in minor or moderate injury.

Dirt and dust adhering to the radiator fins reduce the cooling performance, causing overheating. Make it a rule to check the radiator fins daily and clean as needed.

Note that a typical radiator is shown in **Figure 8** for illustrative purposes only.

- Blow off dirt and dust from fins and radiator with 28 psi (0.19 MPa, 2 kgf/cm²) or less of compressed air (1, **Figure 8**). Be careful not to damage the fins with the compressed air.

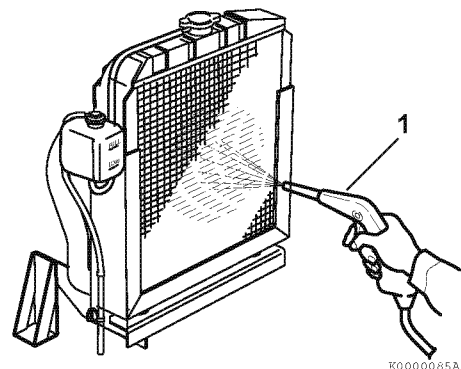

Figure 8

- If there is a large amount of contamination on the fins, apply detergent, thoroughly clean and rinse with tap water.

NOTICE

Never use high-pressure water or compressed air at greater than 28 psi (193 kPa; 19686 mmAq) or a wire brush to clean the radiator fins. Radiator fins damage easily.

PERIODIC MAINTENANCE

■ Check and adjust cooling fan V-belt

Check and adjust the cooling fan V-belt every 250 hours of operation after the initial 50 hour V-belt maintenance. See *Check and adjust cooling fan V-belt* on page 72.

■ Clean air cleaner element

⚠ CAUTION

Flying Object Hazard!

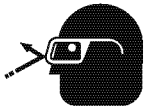

- Always wear eye protection when servicing the engine and when using compressed air or high-pressure water. Dust, flying debris, compressed air, pressurized water or steam may injure your eyes.

- Failure to comply may result in minor or moderate injury.

Note that a typical air cleaner is shown in **Figure 9** and **Figure 10** for illustrative purposes only.

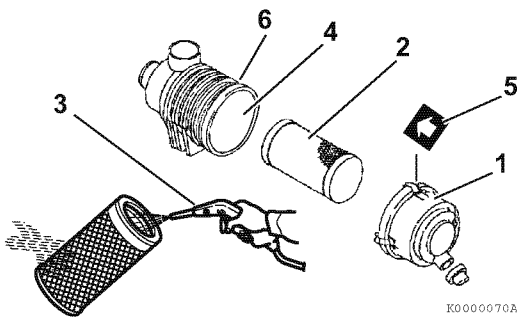

Figure 9

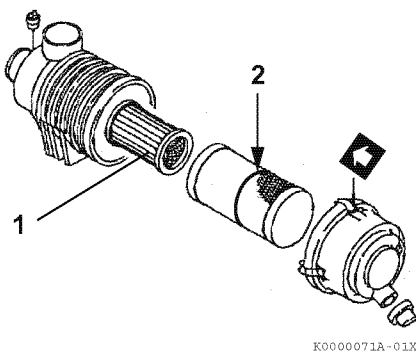

Figure 10

The engine performance is adversely affected when the air cleaner element is clogged with dust. Be sure to clean the air filter element periodically.

1. Unlatch and remove the air cleaner cover (1, **Figure 9**).
2. Remove the element (2, **Figure 9**) (outer element if equipped with two elements).
3. Blow air (3, **Figure 9**) through the element from the inside out using 42 - 71 psi (0.29 - 0.49 MPa, 3.0 - 5.0 kgf/cm²) compressed air to remove the particulates. Use the lowest possible air pressure to remove the dust without damaging the element.
4. If the air cleaner is equipped with a double element, only remove and replace the inner element (1, **Figure 10**) if the engine lacks power or the dust indicator actuates (if equipped).

Note: The inner element should not be removed when cleaning or replacing the outer element. The inner element is used to prevent dust from entering the engine while servicing the outer element.

5. Replace the element with a new one if the element is damaged, excessively dirty or oily.
6. Clean inside of the air cleaner cover.
7. Reinstall the element into the air cleaner case (4, **Figure 9**).

*Note: If there is a red line (2, **Figure 10**) in the outer element, reinsert the element until the overlap position of red line and end face of the air cleaner case.*

8. Reinstall the air cleaner cover making sure you match the arrow (5, **Figure 9**) on the cover with the arrow on the case (6, **Figure 9**).
9. Latch the air cleaner cover to the case.

NOTICE

- When the engine is operated in dusty conditions, clean the air cleaner element more frequently.
- Never operate the engine with the air cleaner element(s) removed. This may allow foreign material to enter the engine and damage it.

Every 500 Hours of Operation

Perform the following maintenance every 500 hours of operation.

- Replace air cleaner element
- Replace fuel filter
- Replace water separator element
- Replace engine lubricating oil and oil filter

■ **Replace air cleaner element**

NOTICE

- The maximum air intake restriction, in terms of differential pressure measurement, must not exceed 0.90 psi (6.23 kPa; 635 mmAq). Clean or replace the air cleaner element if the air intake restriction exceeds the above mentioned value.
- Be sure to use designated element when replacing the air cleaner element.

Replace the air cleaner element (2, **Figure 9**) every 500 hours even if it is not damaged or dirty.

When replacing the element, clean the inside of the air cleaner case (4, **Figure 9**).

If the air cleaner is equipped with a double element, only remove and replace the inner element (1, **Figure 10**) if the engine lacks power or the dust indicator actuates (if equipped). This is in addition to replacing the outer element.

■ **Replace fuel filter**

⚠ DANGER

Fire and Explosion Hazard!



- Diesel fuel is flammable and explosive under certain conditions.

- When you remove any fuel system component to perform maintenance (such as changing the fuel filter) place an approved container under the opening to catch the fuel.
- Never use a shop rag to catch the fuel. Vapors from the rag are flammable and explosive.
- Wipe up any spills immediately.
- Wear eye protection. The fuel system is under pressure and fuel could spray out when you remove any fuel system component.
- Failure to comply will result in death or serious injury.

NOTICE

For maximum engine life, YANMAR recommends that when shutting the engine down, you allow the engine to idle, without load, for five minutes. This will allow the engine components that operate at high temperatures, such as the turbocharger (if equipped) and exhaust system, to cool slightly before the engine itself is shut down.

NOTICE



- Always be environmentally responsible.

- Follow the guidelines of the EPA or other governmental agencies for the proper disposal of hazardous materials such as engine oil, diesel fuel and engine coolant. Consult the local authorities or reclamation facility.
- Never dispose of hazardous materials irresponsibly by dumping them into a sewer, on the ground, or into ground water or waterways.
- Failure to follow these procedures may seriously harm the environment.

Replace the fuel filter every 500 hours of operation to prevent contaminants from adversely affecting the diesel fuel flow.

1. Stop the engine and allow it to cool.
2. Close the fuel valve of the water separator.
3. Remove the fuel filter using a filter wrench to turn it to the left (1, **Figure 11**). When removing the fuel filter, carefully hold it to prevent the fuel from spilling. Wipe up all spilled fuel.

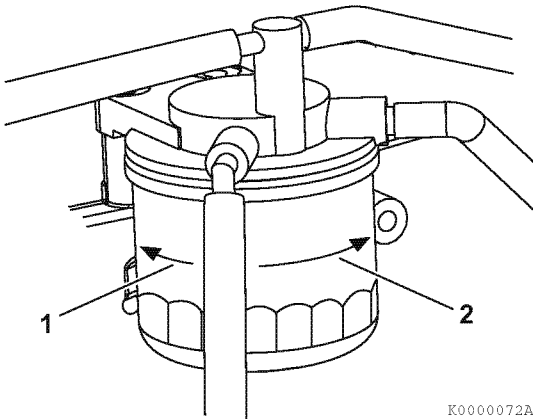

Figure 11

4. Clean the filter mounting surface and apply a small amount of diesel fuel to the gasket of the new fuel filter.

5. Install the new fuel filter. Hand-tighten it to the right (2, **Figure 11**) until it comes in contact with the mounting surface. Use a filter wrench and tighten to 14 - 17 ft-lb (19.6 - 23.5 N·m, 2.0 - 2.4 kgf·m) or one additional turn using the filter wrench.

Fuel filter Part No.
129A00-55800

6. Open the fuel valve of the water separator.
7. Prime the fuel system. *See Priming the Fuel System on page 52.*
8. Check for fuel leaks.

NOTICE

- Be sure to use YANMAR genuine filter for replacing the fuel filter.
- Be sure to perform priming the engine before starting. If air is mixed to the fuel, seizure to the supply pump and the injector may result.

■ Replace water separator element

⚠ DANGER

Fire and Explosion Hazard!



- Diesel fuel is flammable and explosive under certain conditions.

- Never use diesel fuel as a cleaning agent.
- When you remove any fuel system component to perform maintenance (such as changing the fuel filter) place an approved container under the opening to catch the fuel.
- Never use a shop rag to catch the fuel. Vapors from the rag are flammable and explosive.
- Wipe up any spills immediately.
- Wear eye protection. The fuel system is under pressure and fuel could spray out when you remove any fuel system component.
- Failure to comply will result in death or serious injury.

NOTICE



- Always be environmentally responsible.

- Follow the guidelines of the EPA or other governmental agencies for the proper disposal of hazardous materials such as engine oil, diesel fuel and engine coolant. Consult the local authorities or reclamation facility.
- Never dispose of hazardous materials irresponsibly by dumping them into a sewer, on the ground, or into ground water or waterways.
- Failure to follow these procedures may seriously harm the environment.

The water separator filtrates impurities such as water, dust, or soil that frequently enters the engine. Replace the fuel filter element every 500 hours of operation.

1. Position an approved container under the cup (1, **Figure 12**) of the water separator to collect the contaminants.
2. Close the fuel valve (3, **Figure 12**) by turning it to (2, **Figure 12**) position.
3. Loosen the drain valve (4, **Figure 12**) and remove the fuel oil and mixed substance. *See Drain water separator on page 74.*
4. Turn the cup (1, **Figure 12**) to the left (10, **Figure 12**) and remove from the bracket. If it comes with a drain sensor, remove the cable in advance.
5. Carefully hold the cup to prevent fuel from spilling. If you spill any fuel, clean up the spill completely.

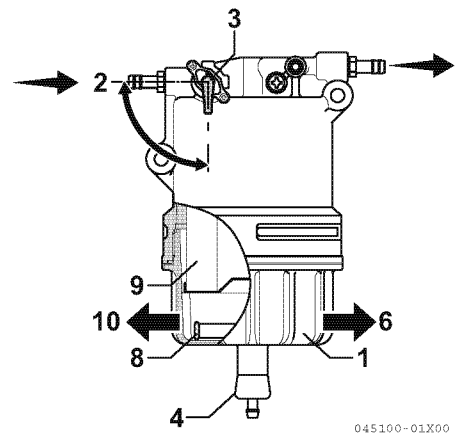

045100-01X00

Figure 12

6. Remove the float ring (8, **Figure 12**) from the cup. If it comes with a drain sensor, there is not float ring. Move the drain inside the cup to the specified container, and dispose with a predetermined method.
 7. Remove the element from the bracket.
 8. Clean the inside cup.
- | Applicable element Part No. | |
|-----------------------------|--------------|
| All models | 129A00-55730 |
9. Check the O-ring of the cup. Replace it if necessary.
 10. Place a float ring inside the cup, and attach the O-ring and the new element in the cup.
 11. Attach the bracket in the cup. Turn to the right (6, **Figure 12**) with a torque of 27 - 33 N·m (2.8 - 3.4 kgf·m). Always tighten with your hand.
 12. Close the drain valve. Reconnect the sensor wire if equipped (tightening torque for valve: 1.0 - 2.0 N·m (0.1 - 0.2 kgf·m).
 13. Open the fuel valve (3, **Figure 12**).
 14. Prime the fuel system. *See Priming the Fuel System on page 52.*
 15. Check for leaks.

NOTICE

- Be sure to use YANMAR genuine element for replacing the water separator element.
- Be sure to perform priming the engine before starting. If air is mixed to the fuel, seizure to the supply pump and the injector may result.

PERIODIC MAINTENANCE

■ Replace engine lubricating oil and oil filter

⚠ WARNING

Burn Hazard!



- If you drain the engine lubricating oil while it is still hot, stay clear of the hot engine lubricating oil to avoid being burned. Always wear eye protection when you handle the engine coolant.

- Always wear eye protection.
- Failure to comply could result in death or serious injury.

NOTICE

- Only use the engine lubricating oil specified. Other engine lubricating oils may affect warranty coverage, cause internal engine components to seize and/or shorten engine life.
- Prevent dirt and debris from contaminating the engine lubricating oil. Carefully clean the oil cap/dipstick and the surrounding area before you remove the cap.
- Never mix different types of engine lubricating oil. This may adversely affect the lubricating properties of the engine lubricating oil.
- Never overfill. Overfilling may result in white exhaust smoke, engine overspeed or internal damage.

NOTICE



- Always be environmentally responsible.

- Follow the guidelines of the EPA or other governmental agencies for the proper disposal of hazardous materials such as engine oil, diesel fuel and engine coolant. Consult the local authorities or reclamation facility.
- Never dispose of hazardous materials irresponsibly by dumping them into a sewer, on the ground, or into ground water or waterways.
- Failure to follow these procedures may seriously harm the environment.

Change the engine lubricating oil every 500 hours or 1 year of operation. Replace the engine oil filter at the same time.

If the engine is equipped with a shallow type oil sump, the maintenance interval for the engine lubricating oil and filter should be every 250 hours regardless of the implement.

Drain the engine lubricating oil as follows:

1. Make sure the engine is level.
2. Start the engine and bring it up to operating temperature.
3. Stop the engine.
4. Remove one of the oil filler caps (1 or 2, **Figure 13**) to vent the engine crankcase and allow the engine lubricating oil to drain more easily.
5. Position a container under the engine to collect waste oil.
6. Remove the oil drain plug (1, **Figure 14**) from the engine oil pan. Allow lubricating oil to drain.
7. After all lubricating oil has been drained from the engine, reinstall the oil drain plug (1, **Figure 14**) and tighten to 40 - 47 ft-lb (53.9 - 63.7 N·m, 5.5 - 6.5 kgf·m).
8. Dispose of used oil properly.

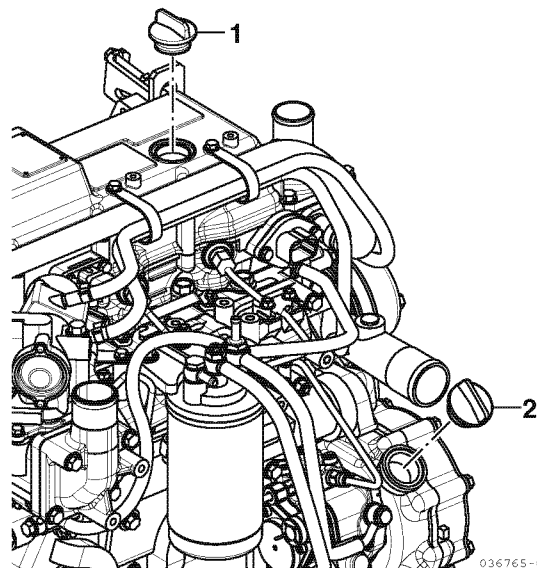
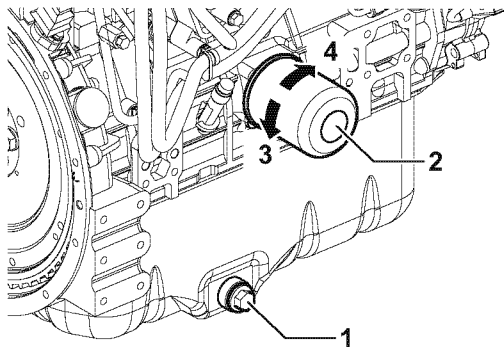

Figure 13

Note: The oil drain plug may be in another location if an optional oil pan is used.

Remove the engine oil filter as follows:

1. Turn the engine oil filter (2, **Figure 14**) counterclockwise (3, **Figure 14**) using an oil filter wrench.



042218-00X00

Figure 14

2. Clean the engine oil filter mounting face.
3. Lightly coat the gasket on the new oil filter with engine lubricating oil. Install the new engine oil filter manually by turning it clockwise (4, **Figure 14**) until it contacts the mounting surface. Tighten to 14 - 17 ft-lb (19.6 - 23.5 N·m, 2.0 - 2.4 kgf·m) or one additional turn using the oil filter wrench.

Engine oil filter Part No.	
Size*	Part No.
80 × 80L	129150-35153
80 × 100L	119005-35151

* The applicable engine filter size varies depending on the engine model. Install the filter of the same size as currently installed.

4. Add new engine lubricating oil to the engine through either of the oil filler ports as specified in *Adding Engine Lubricating Oil* on page 54.

NOTICE

- Be sure to use YANMAR genuine filter for replacing the engine lubricating oil filter.
- Never overfill the engine with engine lubricating oil.
- Always keep the oil level between the upper and lower lines on the oil cap/dipstick.

5. Warm up the engine by running it for 5 minutes and check for any engine lubricating oil leaks.
6. After engine is warm, shut it off and let it sit for 10 minutes.
7. Recheck the engine oil level.
8. Add engine oil to engine lubricating oil filler port (5, **Figure 15**) as needed until the level is between the upper (2, **Figure 15**) and lower lines (3, **Figure 15**) shown on the dipstick (1, **Figure 15**).
9. Reinstall the oil filler cap (4, **Figure 15**). If any engine lubricating oil is spilled, wipe it away with a clean cloth.

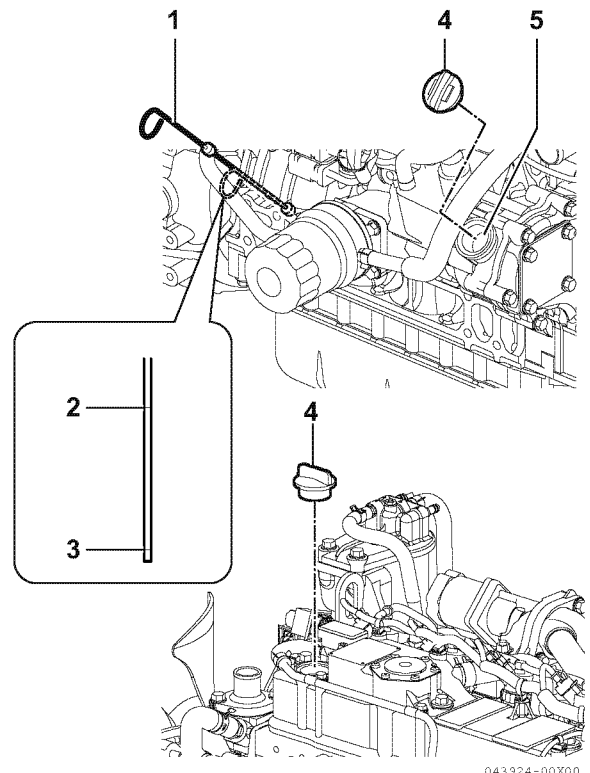

043924-00X00

Figure 15

PERIODIC MAINTENANCE

Every 1000 Hours of Operation

Perform the following maintenance every 1000 hours of operation.

- **Check and adjust intake/exhaust valve clearance**
- **Check and adjust intake/exhaust valve clearance**

Improper intake/exhaust valve clearance will cause the engine to run noisily, resulting in poor engine performance and engine damage. Proper adjustment is necessary to maintain the correct timing for opening and closing the valves. See your authorized YANMAR industrial engine dealer or distributor to inspect and adjust the intake/exhaust valve clearance.

Every 1500 Hours of Operation

Perform the following maintenance every 1500 hours of operation.

- **Inspect crankcase breather system**
- **Inspect crankcase breather system**

Proper operation of the crankcase breather system is required to maintain the emission requirements of the engine. The EPA/ARB requires that you have the crankcase breather system inspected every 1500 hours. See your authorized YANMAR industrial engine dealer or distributor for this service.

Every 2000 Hours of Operation

Perform the following maintenance every 2000 hours of operation.

- **Inspect and replace fuel line, coolant line, lubricating oil line, and breather hose**
- **Change engine coolant**
- **Inspect and replace fuel line, coolant line, lubricating oil line, and breather hose**

Regularly inspect the hoses used for fuel line, coolant line, turbocharger lubricating oil return line, or breather hoses. If they are cracked or degraded, replace them. Replacement of the hoses should be done either 2000 hours of operation or after 2 years, whichever comes first. See your authorized YANMAR industrial engine dealer or distributor to replace fuel hoses and engine coolant system hoses.

- **Change engine coolant**

⚠ DANGER

Scald Hazard!



- **Never remove the radiator cap if the engine is hot. Steam and hot engine coolant will spurt out and seriously burn you. Allow the engine to cool down before you attempt to remove the radiator cap.**
- **Tighten the radiator cap securely after you check the radiator. Steam can spurt out during engine operation if the cap is loose.**
- **Always check the level of the engine coolant by observing the reserve tank.**
- **Failure to comply will result in death or serious injury.**

⚠ WARNING

Burn Hazard!



- Wait until the engine cools before you drain the engine coolant. Hot engine coolant may splash and burn you.

- Failure to comply could result in death or serious injury.

⚠ CAUTION

Engine Coolant Hazard!

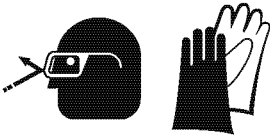

- Wear eye protection and rubber gloves when you handle long life or extended life engine coolant. If contact with the eyes or skin should occur, flush eyes and wash immediately with clean water.

- Failure to comply may result in minor or moderate injury.

NOTICE



- Be responsible to the environment. Follow these procedures for hazardous waste disposal. Failure to follow these procedures may seriously harm the environment.
- Follow the guidelines of the EPA or other governmental agencies for the proper disposal of hazardous materials such as engine oil, diesel fuel and engine coolant. Consult the local authorities or reclamation facility.
- Never dispose of hazardous materials irresponsibly by dumping them into a sewer, on the ground, or into ground water or waterways.

Engine coolant contaminated with rust or water scale reduces the cooling effect. Even when extended life engine coolant is properly mixed, the engine coolant gets contaminated as its ingredients deteriorate. Change engine coolant once 2 years regardless of the periodic maintenance interval.

1. Remove the radiator cap (1, **Figure 16**).
2. Loosen the drain plug or open the drain valve (2, **Figure 16**) at the bottom of the radiator and drain the engine coolant.

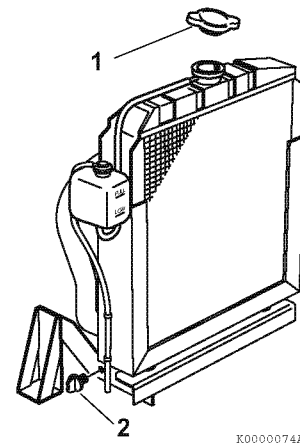

Figure 16

3. Drain the engine coolant from the engine block.
 - Remove the coolant hose (1, **Figure 17**) from the oil cooler if your machine is equipped with an oil cooler.

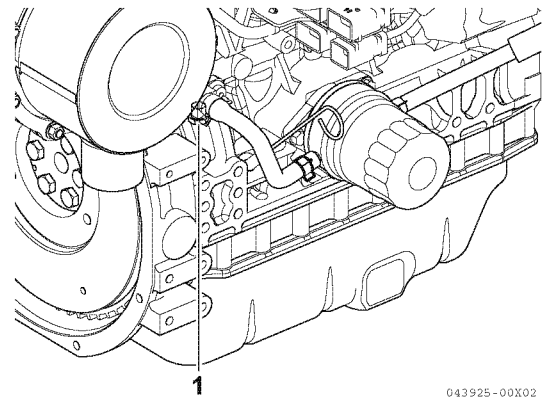

Figure 17

4. After draining the engine coolant, reinstall and tighten the drain plug or close the drain valve in the radiator. Reinstall and tighten the engine block drain plug or reconnect the coolant hose at the oil cooler if your machine is equipped with an oil cooler.
5. Fill radiator and engine with engine coolant. *See Filling Radiator with Engine Coolant on page 56.*

Every 3000 Hours of Operation

Perform the following maintenance every 3000 hours of operation.

- Inspect ECU and related sensors and actuators
- Inspect turbocharger (blower wash as necessary)
3TNV86CT, 4TNV86CT, 4TNV98CT, 4TNV94CHT
- Inspect, clean and test EGR valve
(except for engines with turbochargers)
- Cleaning the EGR cooler
(water side/exhaust passage blower)
- Inspect DPF DOC
- Inspect and test intake throttle valve
- Inspect and test exhaust throttle valve
(optional)
- Check and clean injector

■ Inspect ECU and related sensors and actuators

Inspect the appearance and wirings of the ECU and related sensors and actuators, and check the occurrence status and error history of the engine failure lamp and warning lamps on the control panel. If necessary, a more detailed checkup can be done using a diagnosis tool (SA-D). For detailed checkup, always contact your authorized YANMAR dealer who can handle SA-D.

■ Inspect turbocharger (blower wash as necessary)

3TNV86CT, 4TNV86CT, 4TNV98CT, 4TNV94CHT

Turbocharger service is required by the EPA/ARB every 3000 hours. Your authorized YANMAR industrial engine dealer or distributor will inspect and blower wash the unit if necessary. If you notice that the engine seems sluggish or the exhaust color is abnormal never wait until the next periodic interval. Have your YANMAR dealer or distributor service the turbocharger as soon as possible.

■ Inspect, clean and test EGR valve (except for engines with turbochargers)

The EGR valve is a key component for cleaning exhaust gas. To prevent the valve from deteriorating in exhaust gas recirculation performance due to carbon accumulation, inspect, clean and test the valve at least every 3000 hours. Contact your YANMAR dealer or distributor for inspecting and washing the EGR valve.

■ Cleaning the EGR cooler (water side/exhaust passage blower)

The EGR cooler is apt to be contaminated with rust and scale that deteriorate the cooling performance. Carbon accumulation in the exhaust gas passage of the cooler hinders circulation of exhaust gas, resulting in deterioration in exhaust gas cleanup performance.

To prevent such a problem, clean the cooler at least every 3000 hours.

Contact your YANMAR dealer or distributor for cleaning the EGR cooler.

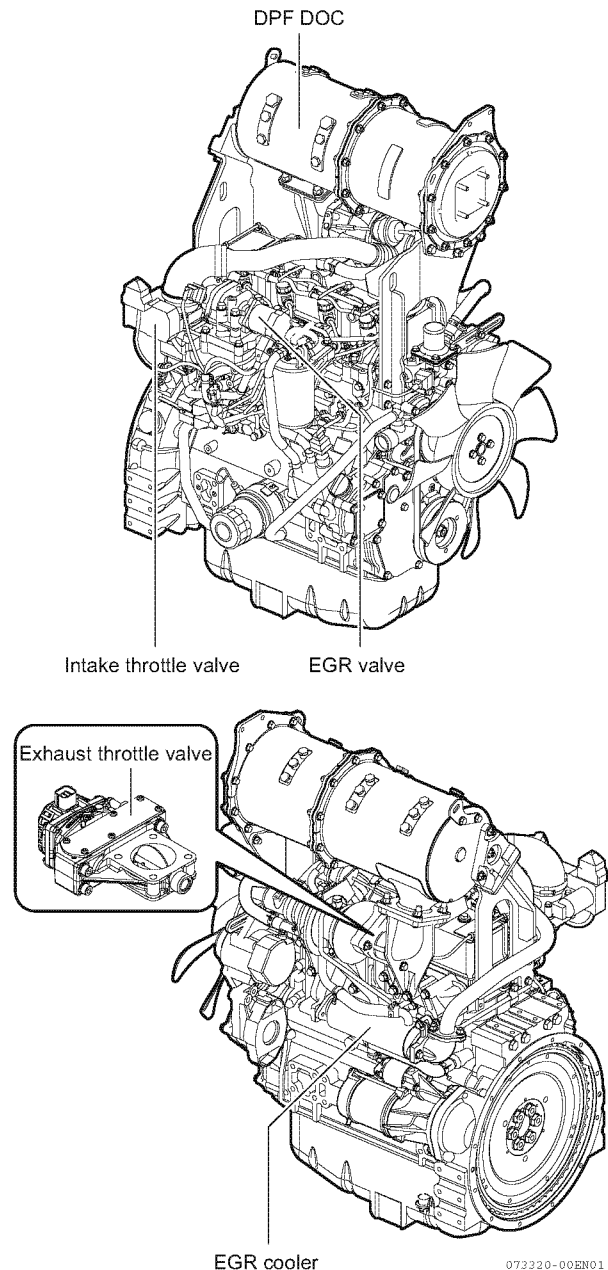

Figure 18

Note: The position of DPF differs depending on the engine.

■ **Inspect DPF DOC**

Inspect the appearance of the DPF exhaust temperature sensor and the differential pressure sensor, and check the after-treatment related occurrence status and error history of the failure lamp and warning lamps on the control panel. If necessary, a more detailed checkup can be done using a diagnosis tool (SA-D).

For detailed checkup, always contact your authorized YANMAR dealer who can handle SA-D.

■ **Inspect and test intake throttle valve**

The intake throttle can affect the exhaust gas treatment performance. Therefore periodic maintenance of the intake throttle is required every 3000 hours of operation.

Contact your YANMAR dealer or distributor for operation check of the intake throttle valve.

■ **Check the operation of exhaust throttle valve (optional)**

Because the exhaust gas property depends on the exhaust throttle, operation check is required every 300 hours.

Contact your YANMAR dealer or distributor for operation check of the exhaust throttle valve.

■ **Check and clean injector**

Check the injector tip.

Clean the injector tip with a soft brush or replace it if necessary.

On 6000 Hours of Operation

Perform the following maintenance on 6000 hours of operation.

- **Check and clean of DPF soot filter**

■ **Check and clean of DPF soot filter**

If your engine is equipped with DPF cleaning alarm, clean the DPF when the alarm lamp comes on.

If your engine is not equipped with DPF cleaning alarm, clean the DPF on 6000 hours of operation.

The cleaning for the DPF soot filter should be done at bases equipped with the cleaning facility.

Contact your authorized YANMAR industrial engine dealer or distributor if you need cleaning.

This Page Intentionally Left Blank

TROUBLESHOOTING

If a problem occurs, stop the engine immediately. Refer to the SYMPTOM column in the Troubleshooting Chart to identify the problem.

NOTICE

If any indicator fails to illuminate when the key switch is in the ON position, see your authorized YANMAR industrial engine dealer or distributor for service before operating the engine.

If any indicator illuminates during engine operation, stop the engine immediately. Determine the cause and repair the problem before you continue to operate the engine.

TROUBLESHOOTING

TROUBLESHOOTING CHART

Symptom	Probable cause	Action	Refer to
Indicator turns ON - engine running			
Engine oil pressure indicator	Low level of engine oil	Check and adjust oil level as necessary	<i>Checking Engine Lubricating Oil on page 54</i>
	Too high an oil level		
	Clogged engine oil filter	Replace engine oil filter	<i>Replace engine lubricating oil and oil filter on page 82</i>
Engine coolant indicator	Low engine coolant level	Add engine coolant	<i>Filling Radiator with Engine Coolant on page 56</i>
	Dirty radiator fins	Clean the radiator fins	<i>Check and clean radiator fins on page 77</i>
	Engine coolant leaking	See authorized YANMAR industrial engine dealer or distributor	–
	V-belt loose or damaged	Adjust V-belt or replace	<i>Check and adjust cooling fan V-belt on page 72</i>
	Contaminated engine coolant	See authorized YANMAR industrial engine dealer or distributor	–
	Faulty engine coolant pump		–
Battery indicator	V-belt loose or damaged	Adjust V-belt or replace	<i>Check and adjust cooling fan V-belt on page 72</i>
	Battery failure	Check battery condition	<i>Check battery on page 75</i>
	Faulty alternator	See authorized YANMAR industrial engine dealer or distributor	–
Indicator does not turn ON - key switch is turned to ON (OFF → ON) - engine not running			
	Faulty electrical wiring or faulty indicator	See authorized YANMAR industrial engine dealer or distributor	–
Indicator stays ON - key switch is turned from START to ON (START → ON) - engine not running			
Battery indicator stays ON	Faulty alternator	See authorized YANMAR industrial engine dealer or distributor	–
Engine oil pressure indicator stays ON	Faulty engine oil pressure switch		–
	No or low level of engine oil	Check and adjust oil level as necessary	<i>Checking Engine Lubricating Oil on page 54</i>
	Clogged engine oil filter	Replace engine oil filter	<i>Replace engine lubricating oil and oil filter on page 82</i>

Symptom	Probable cause	Action	Refer to
Engine does not start			
Starter motor operates but engine does not start	No diesel fuel	Refuel and prime fuel system	<i>Filling the Fuel Tank on page 51</i>
	Air in fuel system	Prime fuel system	<i>Priming the Fuel System on page 52</i>
	Improper diesel fuel	Replace with recommended diesel fuel	<i>Diesel Fuel Specifications on page 48</i>
	Clogged fuel filter	Replace fuel filter	<i>Replace fuel filter on page 79</i>
	Poor fuel injection	See authorized YANMAR industrial engine dealer or distributor	–
	Compressed air leakage from intake/exhaust valves		–
	Faulty engine stop solenoid		–
Starter motor does not operate or rotates too slowly (engine can be turned manually)	Battery needs charging	Check electrolyte, recharge	<i>Check battery on page 75</i>
	Faulty cable connection at battery terminals	Clean terminals, retighten	–
	Faulty key switch	See authorized YANMAR industrial engine dealer or distributor	–
	Faulty starter motor		–
Engine cannot be manually turned	Inner parts seized or damaged		–
White or black exhaust smoke			
Black exhaust smoke	Engine overloaded	Reduce load	–
	Clogged air cleaner element	Clean element or replace	<i>Clean air cleaner element on page 78</i>
	Improper diesel fuel	Replace with recommended diesel fuel	<i>Diesel Fuel Specifications on page 48</i>
	Faulty spraying of fuel injection	See authorized YANMAR industrial engine dealer or distributor	–
	Excessive intake/exhaust valve clearance		–
	Faulty EGR valve		–
White exhaust smoke	Improper diesel fuel	Replace with recommended diesel fuel	<i>Diesel Fuel Specifications on page 48</i>
	Faulty spray pattern of fuel injection	See authorized YANMAR industrial engine dealer or distributor	–
	Fuel injection timing delay		–
	Engine burning oil		–

TROUBLESHOOTING INFORMATION

If your engine does not operate properly, refer to the troubleshooting chart or consult your authorized YANMAR industrial engine dealer or distributor.

Supply the authorized YANMAR industrial engine dealer or distributor with the following information:

- Model name and serial number of your engine
- The driven machine type (tractor, generator, skid steer loader), manufacturer's name, model and serial number
- How long the engine has been in service (the number of engine hours or the number of calendar months)
- Operating conditions when problem occurs:
 - Engine RPM
 - Color of exhaust smoke
 - Type of diesel fuel
 - Type of engine lubricating oil
 - Flashing patterns of fault indicator lamp
 - Any abnormal noises or vibration
- Operating environment such as high altitude or extreme ambient temperatures, etc.
- Engine maintenance history and previous problems
- Other factors that contribute to the problem

TROUBLESHOOTING OF ELECTRONIC CONTROL SYSTEM

The electronically controlled engine with built-in common rail system is equipped with a engine failure lamp. The following section describes how to detect faults on those engines.

Fault Detection Capability

On the electronically controlled engine, the ECU performs various kinds of self-diagnosis based on the information from the sensor for electronic control and various types of preset engine fault detection sensors. According to the status of each sensor, you can set the operations during a fault (optional). When such a fault is detected, the ECU indicates occurrence of failure.

ECU turns on the engine failure lamp, and the indicator indicates that the fault is detected.

The engine failure lamp comes on for approximately 2 seconds when the key switch is turned on, then goes off. With this lamp, you can check whether the power is supplied to ECU.

The engine failure lamp is located on the panel as shown in (1, Figure 1).

NOTICE

Shut down the engine if the engine failure lamp comes on. Continuing running the engine with the engine failure lamp being on may result in a serious malfunction of or damage to the engine, and will void the engine warranty.

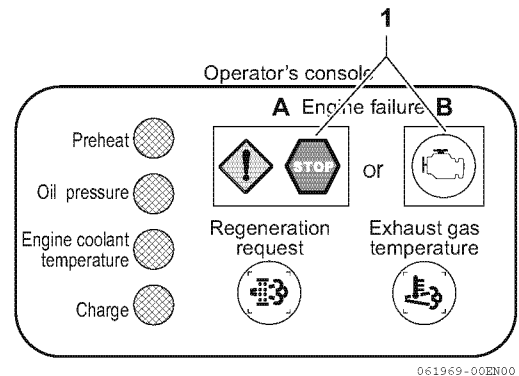

Figure 1

Note: This figure is for reference only. The gauges located on the operator's console may vary depending on the machine. Refer to the operation manual provided by the driven machine manufacturer for details.

Figure 2 exemplifies flashing patterns of the engine failure lamp.

The engine failure lamp comes on for approximately 2 seconds when the switch is turned on, and goes off while the engine is running. If a fault occurs in ECU, this indicator lamp will come on 3 seconds after the indicator lamp goes off, and the lamp continuously stays on. If a fault occurs while the engine is running, the engine failure lamp comes on at the time of fault occurrence.

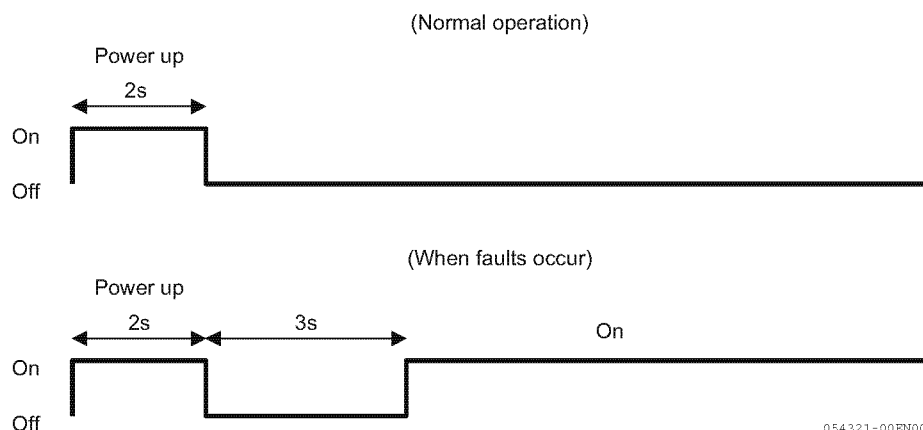

Figure 2

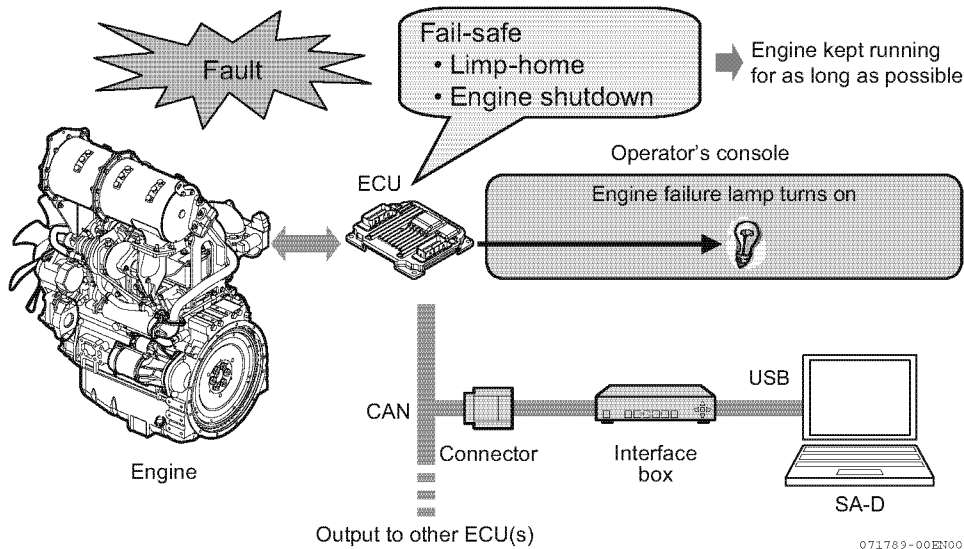

Figure 3

NOTICE

If the engine failure lamp comes on, stop the engine immediately and contact your local YANMAR dealer.

As shown in **Figure 3**, SMARTASSIST-DIRECT (SA-D), YANMAR genuine diagnosis tool, is required to connect to your engine for fault diagnosis. SA-D allows reviewing detailed fault information, historical fault/alarm logs and freeze frame data. In addition, you can monitor the engine status and perform the fault diagnosis by using SMARTASSIST-DIRECT. Events in the fault/alarm logs can be time stamped.

SMARTASSIST-DIRECT (SA-D)

When the ECU or injectors are replaced, you need to rewrite the individual data inside the ECU.

A special treatment is also necessary when replacing DPF or sensors that affects the electronic control system.

A connector is provided at an end of the harness of the driven machine so that the YANMAR genuine SMARTASSIST DIRECT (SA-D) can be loaded with data from the ECU. See **Figure 4** and **Figure 5**.

Contact your authorized YANMAR industrial engine dealer or distributor that can handle SA-D to repair or replace the electronic control parts. Also, refer to the SMARTASSIST-DIRECT operation manual for the detailed operation.

WARNING

- Never use the ECU for purposes that are not intended by YANMAR; such as using unauthorized ECU, writing unauthorized data to ECU, leaving it broken, or removing sensors and actuators. Doing so could result in the violation of emission control regulations and will void the product warranty.
- Be sure to use the ECU in conjunction with the engines whose models or serial numbers are specified by YANMAR. Other ECU/engine combinations than specified will void the engine warranty.
- When replacing the fuel injector, you need to rewrite the fuel injection quantity adjustment data in the ECU. When replacing the ECU, you need to export data from the existing ECU to the new ECU. In order to operate as above, you need to connect the YANMAR genuine SA-D. Be sure to contact your authorized YANMAR dealer who can handle SMARTASSIST-DIRECT (SA-D). ECU that does not have the proper fuel injection quantity adjustment data written, or ECU that does not have the data transferred correctly will void the engine warranty.
- You will also need to connect to SA-D for replacing other CR related items, so be sure to contact your authorized YANMAR dealer if needed.
- Improper use or misuse of the ECU may result in death or serious injury due to an abrupt and unexpected increase in engine speed.

NOTICE

- Do not plug or unplug the ECU for a period of at least 60 seconds after power to the unit has been turned on or off.
- Do not touch connector pins of the ECU with bare hands. Doing so may result in corrosion of the connector pins and/or damage to the internal circuits of the ECU due to static electricity.
- Do not force a measuring probe into the female coupler. Doing so may cause contact failure of the connector pins, resulting in malfunction of the ECU.
- Take care to prevent water from entering the couplers when plugging or unplugging the connector. Water inside the couplers may cause corrosion, resulting in malfunction of the ECU.
- Avoid plugging/unplugging the connector more than approx. 10 times. Frequent plugging/unplugging of the connector may cause contact failure of the connector pins, resulting in malfunction of the ECU.
- Do not use the ECU that has ever suffered drop impact.
- Do not disassemble the ECU terminal.

■ About SA-D use

SA-D is a diagnosis tool that automatically transmits the following information to the YANMAR data server (SMARTASSIST CORE (SA-C)) from the ECU equipped in your driven machine via the Internet.

- Injector, exhaust gas post-treatment equipment, parts replacement information for controllers that are necessary for exhaust gas warranty claims.
- Accumulated operation information required for the reuse of exhaust gas post-treatment equipment.
- Operation history of an engine including fault history, operation time, engine speed, and load ratio.

All the obtained data will be used for the following purposes.

- To prevent improper service in the market
- To provide more accurate and prompt service
- To improve product quality through YANMAR Research and Development

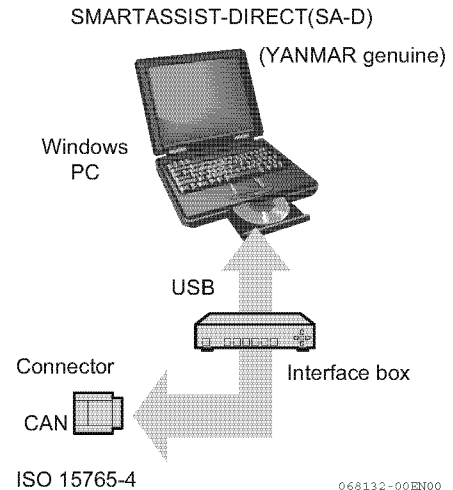
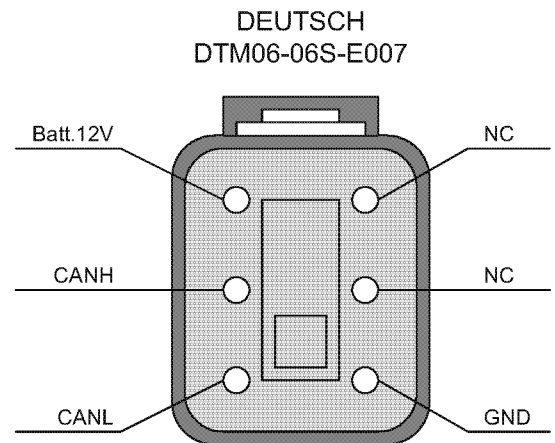

Figure 4



Mating connector (SMARTASSIST-DIRECT side)
DEUTSCH
DTM04-06P-E003

Figure 5

TROUBLESHOOTING FOR ELECTRONIC CONTROL SYSTEM

As a result of periodical checkup, or a result of failure diagnosis done by SA-D after the engine failure lamp is lit, if repair or replacement is needed for the parts in the electronic control system, the equipments that form the system cannot be repaired individually. From the result of the failure diagnosis, you will need to follow TNV series Troubleshooting Manual and replace the applying part or the applying assembly. See TNV series Troubleshooting Manual for details.

The following parts are used for the calculation of the accumulated PM amount in the Diesel Particulate Filter (DPF), so when there is a fault in these parts, the accumulated PM amount may be miscalculated. Therefore, be sure to check the accumulated PM amount using the SMARTASSIST DIRECT (SA-D) when you replace the parts. Processing the DPF regeneration may be necessary depending on the accumulated PM amount.

- Injector
- Supply pump
- EGR valve
- DPF differential pressure sensor
- DPF inside temperature sensor
- Intake manifold temperature sensor
- Exhaust manifold temperature sensor
- Fuel temperature sensor
- DOC
- Rail
- Intake throttle
- DPF inlet temperature sensor
- EGR pressure sensor
- EGR gas temperature sensor
- Crankshaft speed sensor
- Cooling water temperature sensor

When the history data could not be inherited from the old ECU at the time of replacing the ECU, process the DPF regeneration and check the accumulated ash amount using the SMARTASSIST DIRECT (SA-D) in accordance with the following procedures.

Contact an authorized Yanmar dealer or distributor for additional information.

LONG-TERM STORAGE

This section of the Operation Manual describes the procedures necessary to place the engine into long-term storage (six months or longer) and how to place it back into operation.

BEFORE YOU PLACE THE ENGINE IN LONG-TERM STORAGE

DANGER

Explosion Hazard!



- Never short out the battery terminals, including when checking the remaining battery charge. This will result in a spark and may cause an explosion or fire. Use a hydrometer to check the remaining battery charge.
- If the electrolyte is frozen, slowly warm the battery before you recharge it.
- Failure to comply will result in death or serious injury.

WARNING

Burn Hazard!



- Batteries contain sulfuric acid. Never allow battery fluid to come in contact with clothing, skin or eyes. Severe burns could result. Always wear safety goggles and protective clothing when servicing the battery. If battery fluid contacts the eyes and/or skin, immediately flush the affected area with a large amount of clean water and obtain prompt medical treatment.
- Failure to comply could result in death or serious injury.

CAUTION

Flying Object Hazard!

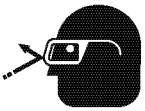

- Always wear eye protection when servicing the engine and when using compressed air or high-pressure water. Dust, flying debris, compressed air, pressurized water or steam may injure your eyes.
- Failure to comply may result in minor or moderate injury.

NOTICE

Protect the air cleaner, turbocharger (if equipped) and electric components from damage when you use steam or high-pressure water to clean the engine.

Perform the next Preventive Maintenance procedure. For example, if there are 10 hours remaining before the 250 hour maintenance, you should do the maintenance before you place the engine in storage.

See Periodic Maintenance Schedule on page 70.

1. Flush the radiator and refill with Long Life Engine Coolant. *See Engine Coolant Specifications on page 56* for engine coolant specifications and *See Filling Radiator with Engine Coolant on page 56* for the procedure for draining and refilling the cooling system.
2. Clean the exterior of the engine so it is free of grease and oil.
3. Drain the fuel tank or make sure it is completely full.
4. Lubricate exposed parts of the engine speed control system.
5. Protect the air cleaner, muffler and electrical components (alternator, starter motor, switches, EGR valve, controller) from water and dust.
6. Disconnect the negative (-) battery cable to prevent the battery from discharging.
7. Check the battery fluid and add distilled water as required. *See Check battery on page 75.*
8. Charge the battery once a month during storage.
9. Rotate the engine without starting, every four to six months.

RETURNING THE ENGINE TO SERVICE

1. Perform the *Daily Checks on page 58*.
2. The engine should be pre-oiled before startup. Crank the engine, leaving the fuel system shut off so the engine will not start, for 15 seconds. Then pause for 30 seconds. Repeat the procedure until you have cranked the engine for a total of one minute. This will circulate the oil in the engine's lubrication system.
3. Prime the fuel system. *See Priming the Fuel System on page 52*.
4. Start the engine. Allow the engine to idle for approximately 15 minutes while you check for:
 - Proper lubricating oil pressure
 - Diesel fuel, engine lubricating oil, or coolant leaks
 - Proper operation of the indicators and/or gauges
5. Avoid prolonged operation at minimum or maximum engine speeds and loads for the remainder of the first hour of operation.

This Page Intentionally Left Blank

SPECIFICATIONS

GENERAL

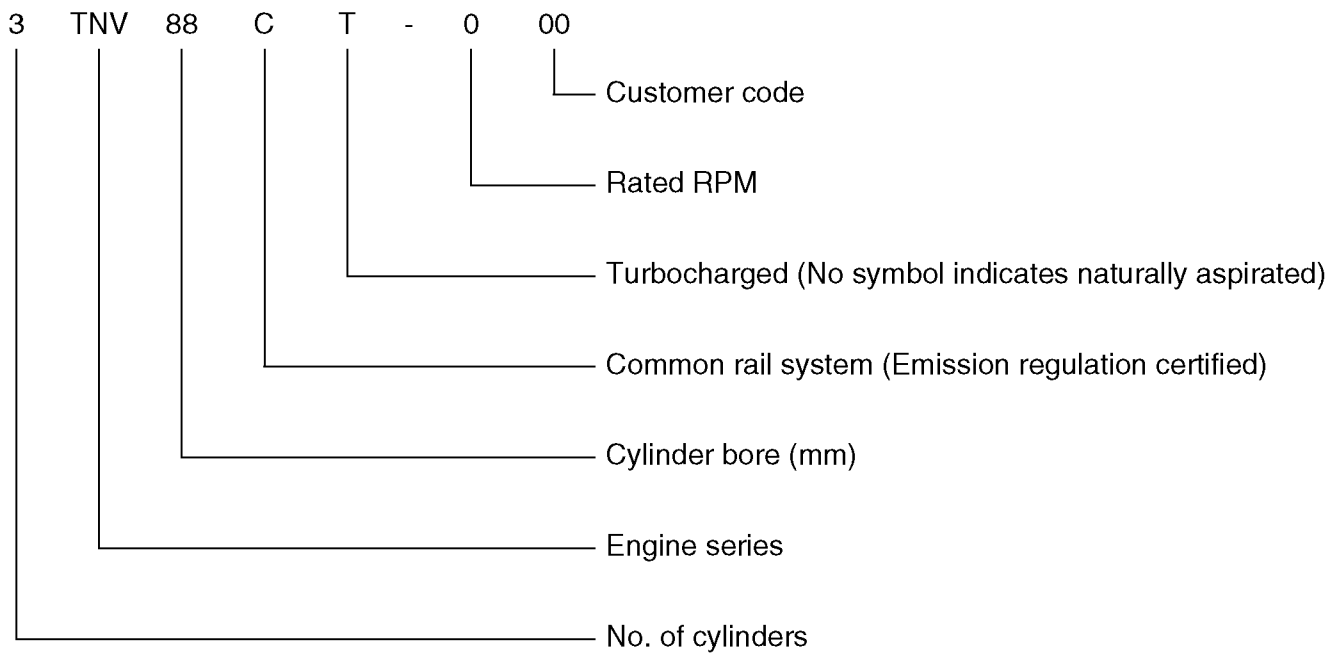

SPECIFICATIONS

Engine General Specifications

Type	Vertical in-line, water cooled, 4-cycle diesel engine
Combustion system	Direct Injection with common rail injection system
Starting system	Electric starting
Cooling system	Radiator
Lubricating system	Forced lubrication with trochoid pump
PTO position	Flywheel end
Direction of rotation	Counterclockwise viewed from flywheel end

Note:

- The information described in *Principal Engine Specifications* is for a “standard” engine. To obtain the information for the engine installed in your driven machine, please refer to the manual provided by the driven machine manufacturer.
- Engine rating conditions are as follows (SAE J1349, ISO 3046/1):
 - Atmospheric condition: Room temperature 25 °C (77 °F), atmospheric pressure 29.53 in. Hg (100 kPa, 750 mmHg), relative humidity 30 %
 - Fuel temperature at fuel injector pump inlet: 40 °C (104 °F)
 - Fuel feeding pressure: 20 ± 10 kPa (net) after engine break-in has been performed with the cooling fan, air cleaner and muffler installed to the engine.
 - With cooling fan, air cleaner, muffler: YANMAR standard
 - After the engine break-in period. Output allowable deviation: ±3 %
 - 1 PS = 0.7355 kW
 - 1 hp SAE (Society of Automotive Engineers) = 0.7457 kW

PRINCIPAL ENGINE SPECIFICATIONS

■ 3TNV88C

Engine model	3TNV88C
Version	VM
Type	Vertical in-line diesel engine (Bosch common rail system)
Combustion system	Direct injection
Aspiration	Naturally aspiration
No. of cylinders	3
Bore x stroke	ø88 x 90 mm
Displacement	1.642 L
Max. rated output (gross)	3000 min ⁻¹
	27.5 kW
	37.4 PS
High idling	3150 ± 25 min ⁻¹
Engine weight (dry)*1	188 kg
PTO position	Flywheel end
Direction of rotation	Counterclockwise viewed from flywheel end
Cooling system	Liquid-cooled with radiator
Lubricating system	Forced lubrication with trochoid pump
Normal oil pressure at rated engine speed	0.34 - 0.54 MPa
Normal oil pressure at low idle speed	0.06 MPa
Starting system	Electric starting (starter motor: DC12 V - 1.7 kW)*3
	Alternator (12 V - 55 A)*3
	Recommended battery capacity: 12 V 413CCA*3
Dimensions (L x W x H)	depend on DPF layout
Engine oil pan capacity*2	6.7/3.9 L Dipstick upper limit/lower Limit
Engine coolant capacity	2.3 L (Engine only)
Standard cooling fan	ø335 mm Pusher*3
Crank V-pulley dia./Fan V-pulley dia.	ø110/ø110 mm
Top clearance	0.73 ± 0.06 mm

*1: Engine specifications without radiator.

*2: Engine oil capacity for a "Deep Standard" oil pan. Refer to the operation manual provided by the driven machine manufacturer for the actual engine oil capacity of your machine.

*3: May vary depending on application.

SPECIFICATIONS

■ 3TNV86CT

Engine model	3TNV86CT
Version	VM
Type	Vertical in-line diesel engine (Bosch common rail system)
Combustion system	Direct injection
Aspiration	Turbocharged
No. of cylinders	3
Bore x stroke	ø86 x 90 mm
Displacement	1.568 L
Max. rated output (gross)	3000 min ⁻¹
	32.4 kW
	44.1 PS
High idling	3150 ± 25 min ⁻¹
Engine weight (dry)*1	200 kg
PTO position	Flywheel end
Direction of rotation	Counterclockwise viewed from flywheel end
Cooling system	Liquid-cooled with radiator
Lubricating system	Forced lubrication with trochoid pump
Normal oil pressure at rated engine speed	0.34 - 0.54 MPa
Normal oil pressure at low idle speed	0.06 MPa
Starting system	Electric starting (starter motor: DC12 V - 1.7 kW)*3
	Alternator (12 V - 55 A)*3
	Recommended battery capacity: 12 V 413CCA*3
Dimensions (L x W x H)	depend on DPF layout
Engine oil pan capacity*2	6.7/3.9 L Dipstick upper limit/lower Limit
Engine coolant capacity	2.3 L (Engine only)
Standard cooling fan	ø350 mm Pusher*3
Crank V-pulley dia./Fan V-pulley dia.	ø110/ø110 mm
Top clearance	0.73 ± 0.06 mm

*1: Engine specifications without radiator.

*2: Engine oil capacity for a "Deep Standard" oil pan. Refer to the operation manual provided by the driven machine manufacturer for the actual engine oil capacity of your machine.

*3: May vary depending on application.

■ **3TNV86CHT**

Engine model	3TNV86CHT
Version	VM
Type	Vertical in-line diesel engine (Bosch common rail system)
Combustion system	Direct injection
Aspiration	Turbocharged
No. of cylinders	3
Bore x stroke	ø86 x 90 mm
Displacement	1.568 L
Max. rated output (gross)	2600 min ⁻¹
	33.3 kW
	45.7 PS
High idling	2750 ± 25 min ⁻¹
Engine weight (dry)*1	200 kg
PTO position	Flywheel end
Direction of rotation	Counterclockwise viewed from flywheel end
Cooling system	Liquid-cooled with radiator
Lubricating system	Forced lubrication with trochoid pump
Normal oil pressure at rated engine speed	0.34 - 0.54 MPa
Normal oil pressure at low idle speed	0.06 MPa
Starting system	Electric starting (starter motor: DC12 V - 1.7 kW)*3
	Alternator (12 V - 55 A)*3
	Recommended battery capacity: 12 V 413CCA*3
Dimensions (L x W x H)	depend on DPF layout
Engine oil pan capacity*2	6.7/3.9 L Dipstick upper limit/lower Limit
Engine coolant capacity	2.3 L (Engine only)
Standard cooling fan	ø375 mm Suction*3
Crank V-pulley dia./Fan V-pulley dia.	ø120/ø120 mm*3
Top clearance	0.73 ± 0.06 mm

*1: Engine specifications without radiator.

*2: Engine oil capacity for a "Deep Standard" oil pan. Refer to the operation manual provided by the driven machine manufacturer for the actual engine oil capacity of your machine.

*3: May vary depending on application.

SPECIFICATIONS

■ 4TNV88C

Engine model	4TNV88C
Version	VM
Type	Vertical in-line diesel engine (Bosch common rail system)
Combustion system	Direct injection
Aspiration	Naturally aspiration
No. of cylinders	4
Bore x stroke	ø88 x 90 mm
Displacement	2.189 L
Max. rated output (gross)	3000 min ⁻¹
	35.5 kW
	48.3 PS
High idling	3150 ± 25 min ⁻¹
Engine weight (dry)*1	220 kg
PTO position	Flywheel end
Direction of rotation	Counterclockwise viewed from flywheel end
Cooling system	Liquid-cooled with radiator
Lubricating system	Forced lubrication with trochoid pump
Normal oil pressure at rated engine speed	0.32 - 0.47 MPa
Normal oil pressure at low idle speed	0.06 MPa
Starting system	Electric starting (starter motor: DC12 V - 1.7 kW)*3
	Alternator (12 V - 55 A)*3
	Recommended battery capacity: 12 V 622CCA*3
Dimensions (L x W x H)	depend on DPF layout
Engine oil pan capacity*2	7.4/4.0 L Dipstick upper limit/lower Limit
Engine coolant capacity	3.0 L (Engine only)
Standard cooling fan	ø370 mm Pusher*3
Crank V-pulley dia./Fan V-pulley dia.	ø110/ø110 mm
Top clearance	0.73 ± 0.06 mm

*1: Engine specifications without radiator.

*2: Engine oil capacity for a "Deep Standard" oil pan. Refer to the operation manual provided by the driven machine manufacturer for the actual engine oil capacity of your machine.

*3: May vary depending on application.

■ **4TNV86CT**

Engine model	4TNV86CT
Version	VM
Type	Vertical in-line diesel engine (Bosch common rail system)
Combustion system	Direct injection
Aspiration	Turbocharged
No. of cylinders	4
Bore x stroke	ø86 x 90 mm
Displacement	2.090 L
Max. rated output (gross)	3000 min ⁻¹
	44.0 kW
	59.8 PS
High idling	3150 ± 25 min ⁻¹
Engine weight (dry)*1	225 kg
PTO position	Flywheel end
Direction of rotation	Counterclockwise viewed from flywheel end
Cooling system	Liquid-cooled with radiator
Lubricating system	Forced lubrication with trochoid pump
Normal oil pressure at rated engine speed	0.36 - 0.51 MPa
Normal oil pressure at low idle speed	0.06 MPa
Starting system	Electric starting (starter motor: DC12 V - 1.7 kW)*3
	Alternator (12 V - 55 A)*3
	Recommended battery capacity: 12 V 622CCA*3
Dimensions (L x W x H)	depend on DPF layout
Engine oil pan capacity*2	7.4/4.0 L Dipstick upper limit/lower Limit
Engine coolant capacity	3.0 L (Engine only)
Standard cooling fan	ø370 mm Pusher*3
Crank V-pulley dia./Fan V-pulley dia.	ø110/ø110 mm
Top clearance	0.73 ± 0.06 mm

*1: Engine specifications without radiator.

*2: Engine oil capacity for a "Deep Standard" oil pan. Refer to the operation manual provided by the driven machine manufacturer for the actual engine oil capacity of your machine.

*3: May vary depending on application.

SPECIFICATIONS

■ 4TNV86CHT

Engine model	4TNV86CHT
Version	VM
Type	Vertical in-line diesel engine (Bosch common rail system)
Combustion system	Direct injection
Aspiration	Turbocharged
No. of cylinders	4
Bore x stroke	ø86 x 90 mm
Displacement	2.090 L
Max. rated output (gross)	2600 min ⁻¹
	48.5 kW
	65.9 PS
High idling	2750 ± 25 min ⁻¹
Engine weight (dry)* ¹	225 kg
PTO position	Flywheel end
Direction of rotation	Counterclockwise viewed from flywheel end
Cooling system	Liquid-cooled with radiator
Lubricating system	Forced lubrication with trochoid pump
Normal oil pressure at rated engine speed	0.36 - 0.51 MPa
Normal oil pressure at low idle speed	0.06 MPa
Starting system	Electric starting (starter motor: DC12 V - 1.7 kW)* ³
	Alternator (12 V - 55 A)* ³
	Recommended battery capacity: 12 V 622CCA* ³
Dimensions (L x W x H)	depend on DPF layout
Engine oil pan capacity* ²	7.4/4.0 L Dipstick upper limit/lower Limit
Engine coolant capacity	3.0 L (Engine only)
Standard cooling fan	ø410 mm Suction* ³
Crank V-pulley dia./Fan V-pulley dia.	ø120/ø110 mm* ³
Top clearance	0.73 ± 0.06 mm

*1: Engine specifications without radiator.

*2: Engine oil capacity for a "Deep Standard" oil pan. Refer to the operation manual provided by the driven machine manufacturer for the actual engine oil capacity of your machine.

*3: May vary depending on application.

■ **4TNV98C**

Engine model	4TNV98C
Version	VM
Type	Vertical in-line diesel engine (Bosch common rail system)
Combustion system	Direct injection
Aspiration	Naturally aspiration
No. of cylinders	4
Bore x stroke	ø98 x 110 mm
Displacement	3.319 L
Max. rated output (gross)	2500 min ⁻¹
	51.7 kW
	70.3 PS
High idling	2650 ± 25 min ⁻¹
Engine weight (dry)* ¹	280 kg
PTO position	Flywheel end
Direction of rotation	Counterclockwise viewed from flywheel end
Cooling system	Liquid-cooled with radiator
Lubricating system	Forced lubrication with trochoid pump
Normal oil pressure at rated engine speed	0.29 - 0.39 MPa
Normal oil pressure at low idle speed	0.06 MPa
Starting system	Electric starting (starter motor: DC12 V - 3.0 kW)* ³
	Alternator (12 V - 55 A)* ³
	Recommended battery capacity: 12 V 799CCA* ³
Dimensions (L x W x H)	depend on DPF layout
Engine oil pan capacity* ²	10.5/6.0 L Dipstick upper limit/lower Limit
Engine coolant capacity	4.5 L (Engine only)
Standard cooling fan	ø410 mm Pusher* ³
Crank V-pulley dia./Fan V-pulley dia.	ø130/ø130 mm
Top clearance	0.793 ± 0.063 mm

*1: Engine specifications without radiator.

*2: Engine oil capacity for a "Deep Standard" oil pan. Refer to the operation manual provided by the driven machine manufacturer for the actual engine oil capacity of your machine.

*3: May vary depending on application.

SPECIFICATIONS

■ 4TNV98CT

Engine model	4TNV98CT
Version	VM
Type	Vertical in-line diesel engine (Bosch common rail system)
Combustion system	Direct injection
Aspiration	Turbocharged
No. of cylinders	4
Bore x stroke	ø98 x 110 mm
Displacement	3.319 L
Max. rated output (gross)	2500 min ⁻¹
	53.7 kW
	73.0 PS
High idling	2650 ± 25 min ⁻¹
Engine weight (dry)*1	291 kg
PTO position	Flywheel end
Direction of rotation	Counterclockwise viewed from flywheel end
Cooling system	Liquid-cooled with radiator
Lubricating system	Forced lubrication with trochoid pump
Normal oil pressure at rated engine speed	0.29 - 0.39 MPa
Normal oil pressure at low idle speed	0.06 MPa
Starting system	Electric starting (starter motor: DC12 V - 3.0 kW)*3
	Alternator (12 V - 55 A)*3
	Recommended battery capacity: 12 V 799CCA*3
Dimensions (L x W x H)	depend on DPF layout
Engine oil pan capacity*2	10.5/6.0 L Dipstick upper limit/lower Limit
Engine coolant capacity	4.5 L (Engine only)
Standard cooling fan	ø430 mm Suction*3
Crank V-pulley dia./Fan V-pulley dia.	ø130/ø130 mm
Top clearance	0.793 ± 0.071 mm

*1: Engine specifications without radiator.

*2: Engine oil capacity for a "Deep Standard" oil pan. Refer to the operation manual provided by the driven machine manufacturer for the actual engine oil capacity of your machine.

*3: May vary depending on application.

■ **4TNV94CHT**

Engine model	4TNV94CHT
Version	VM
Type	Vertical in-line diesel engine (Denso common rail system)
Combustion system	Direct injection
Aspiration	Turbocharged
No. of cylinders	4
Bore x stroke	ø94 x 110 mm
Displacement	3.053 L
Max. rated output (gross)	2500 min ⁻¹
	88.4 kW
	120.2 PS
High idling	2700 ± 10 min ⁻¹
Engine weight (dry)* ¹	290 kg
PTO position	Flywheel end
Direction of rotation	Counterclockwise viewed from flywheel end
Cooling system	Liquid-cooled with radiator
Lubricating system	Forced lubrication with trochoid pump
Normal oil pressure at rated engine speed	0.44 MPa
Normal oil pressure at low idle speed	0.06 MPa
Starting system	Electric starting (starter motor: DC12 V - 3.0 kW)* ³
	Alternator (12 V - 55 A)* ³
	Recommended battery capacity: 12 V 799CCA* ³
Dimensions (L x W x H)	depend on DPF layout
Engine oil pan capacity* ²	12.6/8.1 L Dipstick upper limit/lower Limit
Engine coolant capacity	4.2 L (Engine only)
Standard cooling fan	ø500 mm Suction* ³
Crank V-pulley dia./Fan V-pulley dia.	ø150/ø150 mm
Top clearance	0.793 ± 0.071 mm

*1: Engine specifications without radiator.

*2: Engine oil capacity for a "Deep Standard" oil pan. Refer to the operation manual provided by the driven machine manufacturer for the actual engine oil capacity of your machine.

*3: May vary depending on application.

SPECIFICATIONS

■ Setting output list by rotation

Model	Displacement (L)	Gross output (kW)									
		2000	2100	2200	2300	2400	2500	2600	2700	2800	3000
3TNV88C	1.642	–	–	–	–	21.8	22.8	23.7	24.6	25.5	27.5
3TNV86CT	1.568	–	–	–	–	–	27.4	28.5	–	31.0	32.4
3TNV86CHT	1.568	–	–	–	–	–	–	33.3	–	–	–
4TNV88C	2.189	24.2	25.4	26.7	27.9	29.1	30.5	31.7	33.0	34.3	35.5
4TNV86CT	2.091	–	–	–	–	35.5	36.6	37.9	39.5	41.1	44.0
4TNV86CHT	2.091	–	–	–	–	–	–	48.5	–	–	–
4TNV98C	3.319	42.4	44.3	46.2	48.1	49.9	51.7	–	–	–	–
4TNV98CT	3.319	51.6	53.7	53.7	53.7	53.7	53.7	–	–	–	–
4TNV94CHT	3.063	–	–	77.2	–	–	88.4	–	–	–	–

YANMAR

Head Office:

YANMAR CO., LTD.

1-32 Chayamachi, Kita-ku, Osaka, Japan
<https://www.yanmar.com>

Yanmar America Corporation

101 International Parkway
Adairsville, GA 30103, U.S.A.
TEL: +1-770-877-9894 FAX: +1-770-877-9009
<http://us.yanmar.com>

Yanmar Europe B.V.

Brugplein11, 1332 BS Almere -de Vaart
The Netherlands.
TEL: +31-36-5493200 FAX: +31-36-5493209
<http://www.yanmar.eu>

Yanmar Asia (Singapore) Corporation Pte Ltd.

4 Tuas Lane, Singapore 638613
TEL: +65-6861-3855 FAX: +65-6862-5189
<https://www.yanmar.com/sg/>

Yanmar Engine (Shanghai) Corporation Ltd.

10F, E-Block Poly Plaza, No.18 Dongfang Road
Pudong Shanghai, China P.R.C. 200120
TEL: +86-21-6880-5090 FAX: +86-21-6880-8682
<https://www.yanmar.com/cn/>

Yanmar South America Industria De Maquinas Ltda.

Av. Presidente Vargas 1400, Indaiatuba, S.P., Brazil, CEP: 13338-901
TEL: +55-19-3801-9224 FAX: +55-19-3875-3899, 2241
<http://www.yanmar.com.br/>

As of May 20, 2015

OPERATION MANUAL

TNV Tier4 Common Rail Series

1st edition: March 2012
6th edition 1st rev.: September 2015
7th edition: January 2016
7th edition 1st rev.: April 2016
8th edition: July 2016

Issued by: YANMAR CO., LTD.

Edited by: YANMAR TECHNICAL SERVICE CO., LTD.



INDUSTRIAL ENGINE

YANMAR

YANMAR CO., LTD.

<https://www.yanmar.com>

0ATN4-EN0017
PRINTED IN JAPAN